

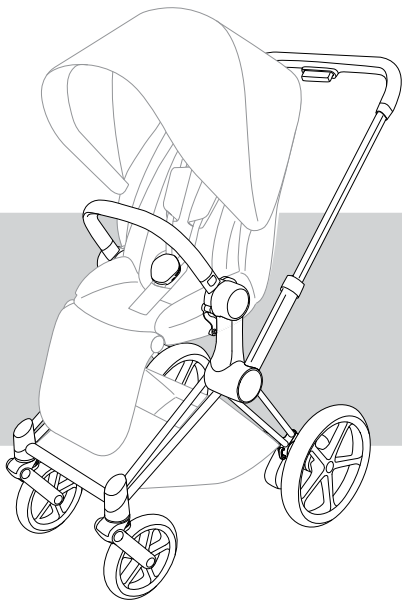

# e·PRIAM

## FRAME & SEAT



Download the  
CYBEX app  
and register your  
product to unlock  
your benefits



**EN** WARNING  
**DE** WARNUNG  
**ES** ADVERTENCIA  
**FR** AVERTISSEMENT  
**PT** AVISOS  
**IT** WARNING  
**NL** WAARSCHUWING  
**PL** OSTRZEŻENIE  
**CS** UPOZORNĚNÍ  
**SK** UPOZORNENIE  
**SL** OPOZORILO  
**HR** UPOZORENJE  
**HU** FIGYELMEZTETÉS  
**SE** VARNING  
**NO** ADVARSEL  
**FI** VAROITUS  
**DA** ADVARSEL  
**ET** HOIATUS  
**LV** BRĪDINĀJUMS  
**LT** PERSPĖJIMAS  
**RU** ВНИМАНИЕ  
**UK** УВАГА  
**TR** UYARI  
**EL** ΠΡΟΕΙΔΟΠΟΙΗΣΗ  
**RO** AVERTISMENTE  
**IS** VIÐVÖRUN  
**MT** TWISSIJA

**AR**  
**FA**  
**YUE** 警告  
**CMN** 警告  
**JA** 警告  
**KO** 경고  
**BG** ПРЕДУПРЕЖДЕНИЕ  
**SR** UPOZORENJE  
**MS** AMARAN  
**HI** चेतावनी  
**TH** คำเตือน  
**SQ** PARALAJMËRIM  
**BS** UPOZORENJE  
**ME** UPOZORENJE  
**MK** ПРЕДУПРЕДУВАЊЕ  
**HY** շՊԻՇԱՑՈՒՄ  
**VI** CẢNH BÁO

تحذير  
اخطار



**EN** Tutorial video  
**DE** Videoanleitung  
**ES** Tutorial en vídeo  
**FR** Vidéo de démonstration  
**PT** Video tutorial  
**IT** Video tutorial  
**NL** Instructievideo  
**PL** Film instruktażowy  
**CS** Výukové video  
**SK** Výukové video  
**SL** Video z navodili  
**HR** Video s uputama  
**HU** Bemutatóvideó  
**SE** Videosjälvstudiekurs  
**NO** Opplæringsvideo  
**FI** Opetusvideo  
**DA** Vejledende video  
**ET** Õppevideo  
**LV** Ar mācību video  
**LT** Mokomasis vaizdo įrašas  
**RU** Обучающее видео  
**UK** Навчальне відео  
**TR** Öğretici video  
**EL** Εκπαιδευτικό βίντεο  
**RO** Video tutorial  
**IS** Kennslumyndband  
**MT** Tutorial fuq vidjow



**AR**

**FA**

**YUE** 教程視頻

**CMN** 教程视频

**JA** チュートリアルビデオ

**KO** 튜토리얼 동영상

**BG** Учебно видео

**SR** Video sa uputstvima

**MS** Video tutorial

**HI** ट्यूटोरियल वीडियो

**TH** วิทยาลัย

**SQ** Video udhëzuese

**BS** Video sa uputstvima

**ME** Video sa uputstvima

**MK** Видеоупатство

**HY** Παιδαγωγικά βίντεο

**VI** Video hướng dẫn

فیدویو تعلیمی  
ویدئوی آموزشی

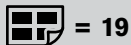

<b>EN</b>	Maximum weights	<b>TR</b>	Maksimum ağırlıklar
<b>DE</b>	Maximalgewichte	<b>EL</b>	Μέγιστο βάρος
<b>ES</b>	Pesos máximos	<b>RO</b>	Greutăți maxime
<b>FR</b>	Poids maximum	<b>IS</b>	Hámarksþyngd
<b>PT</b>	Pesos máximos	<b>MT</b>	Piżijiet massimi
<b>IT</b>	Peso massimo	<b>AR</b>	الأوزان القصوى
<b>NL</b>	Maximumgewicht	<b>FA</b>	حداکثر وزن
<b>PL</b>	Dopuszczalna waga	<b>YUE</b>	最大重量
<b>CS</b>	Maximální hmotnosti	<b>CMN</b>	最大重量
<b>SK</b>	Maximálne hmotnosti	<b>JA</b>	最大重量
<b>SL</b>	Največje teže	<b>KO</b>	최대 하중
<b>HR</b>	Maksimalne težine	<b>BG</b>	Максимални тегла
<b>HU</b>	Maximális súlyok	<b>SR</b>	Maksimalne težine
<b>SE</b>	Max.vikter	<b>MS</b>	Berat maksimum
<b>NO</b>	Maksimumsvektor	<b>HI</b>	अधिकतम वजन
<b>FI</b>	Enimmäispainot	<b>TH</b>	น้ำหนักสูงสุด
<b>DA</b>	Maksimumvægt	<b>SQ</b>	Peshat maksimale
<b>ET</b>	Maksimaalne kaal	<b>BS</b>	Maksimalne težine
<b>LV</b>	Maksimālais svars	<b>ME</b>	Maksimalne težine
<b>LT</b>	Didžiausi svoriai	<b>MK</b>	Максимални тежини
<b>RU</b>	Максимальная масса	<b>HY</b>	Առավելագույն քաշեր
<b>UK</b>	Максимальна вага	<b>VI</b>	Các mức cân nặng tối đa

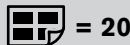

<b>EN</b>	Product registration	<b>TR</b>	Ürün kaydı
<b>DE</b>	Produktregistrierung	<b>EL</b>	Καταχώριση προϊόντος
<b>ES</b>	Registro del producto	<b>RO</b>	Înregistrarea produsului
<b>FR</b>	Enregistrement du produit	<b>IS</b>	Skráning tækis
<b>PT</b>	Registo do produto	<b>MT</b>	Reġistrazzjoni tal-prodott
<b>IT</b>	Registrazione del prodotto	<b>AR</b>	تسجيل المنتج
<b>NL</b>	Productregistratie	<b>FA</b>	ثبت محصول
<b>PL</b>	Rejestracja produktu	<b>YUE</b>	產品註冊
<b>CS</b>	Registrace výrobku	<b>CMN</b>	产品注册
<b>SK</b>	Registrácia výrobku	<b>JA</b>	製品の登録
<b>SL</b>	Registracija izdelka	<b>KO</b>	제품 등록
<b>HR</b>	Registracija proizvoda	<b>BG</b>	Регистрация на продукта
<b>HU</b>	Termékregisztráció	<b>SR</b>	Registracija proizvoda
<b>SE</b>	Produktregistrering	<b>MS</b>	Pendaftaran produk
<b>NO</b>	Produktregistrering	<b>HI</b>	उत्पाद पंजीकरण
<b>FI</b>	Tuotteen rekisteröinti	<b>TH</b>	การลงทะเบียนผลิตภัณฑ์
<b>DA</b>	Produktregistrering	<b>SQ</b>	Regjistrimi i produktit
<b>ET</b>	Toote registreerimine	<b>BS</b>	Registracija proizvoda
<b>LV</b>	Produkta reģistrācija	<b>ME</b>	Registracija proizvoda
<b>LT</b>	Gaminio registracija	<b>MK</b>	Регистрација на производ
<b>RU</b>	Регистрация продукта	<b>HY</b>	Արձանագր գրանցում
<b>UK</b>	Реєстрація продукту	<b>VI</b>	Đăng ký sản phẩm



 = 21

<b>EN</b>	Set up	<b>TR</b>	Kurulum
<b>DE</b>	Aufbau	<b>EL</b>	Στήσιμο
<b>ES</b>	Instalación	<b>RO</b>	Setare
<b>FR</b>	Montage	<b>IS</b>	Uppsetning
<b>PT</b>	Preparação	<b>MT</b>	Konfigurazzjoni
<b>IT</b>	Configurazione	<b>AR</b>	
<b>NL</b>	Opbouw	<b>FA</b>	تنصيب برپا کردن
<b>PL</b>	Montaż	<b>YUE</b>	設置
<b>CS</b>	Nastavení	<b>CMN</b>	设置
<b>SK</b>	Nastavenie	<b>JA</b>	セットアップ
<b>SL</b>	Nastavitev	<b>KO</b>	설정
<b>HR</b>	Postavljanje	<b>BG</b>	Настройка
<b>HU</b>	Felszerelés	<b>SR</b>	Postavljanje
<b>SE</b>	Inställning	<b>MS</b>	Persediaan
<b>NO</b>	Oppsett	<b>HI</b>	सेट अप
<b>FI</b>	Asennus	<b>TH</b>	การติดตั้ง
<b>DA</b>	Opsætning	<b>SQ</b>	Konfigurimi
<b>ET</b>	Seadistamine	<b>BS</b>	Postavljanje
<b>LV</b>	Uzstādīšana	<b>ME</b>	Postavljanje
<b>LT</b>	Nuostatos	<b>MK</b>	Поставување
<b>RU</b>	Установка	<b>HY</b>	Շարժափոխում
<b>UK</b>	Встановлення	<b>VI</b>	Cài đặt



 = 39

<b>EN</b>	Battery	<b>TR</b>	Batarya
<b>DE</b>	Batterie	<b>EL</b>	Μπαταρία
<b>ES</b>	Batería	<b>RO</b>	Baterie
<b>FR</b>	Pile	<b>IS</b>	Rafhlaða
<b>PT</b>	Bateria	<b>MT</b>	Batterija
<b>IT</b>	Batteria	<b>AR</b>	
<b>NL</b>	Batterij	<b>FA</b>	بطارية باتری
<b>PL</b>	Bateria	<b>YUE</b>	電池
<b>CS</b>	Baterie	<b>CMN</b>	电池
<b>SK</b>	Batéria	<b>JA</b>	バッテリー
<b>SL</b>	Baterija	<b>KO</b>	배터리
<b>HR</b>	Baterija	<b>BG</b>	Батерия
<b>HU</b>	Elem	<b>SR</b>	Baterija
<b>SE</b>	Batteri	<b>MS</b>	Bateri
<b>NO</b>	Batteri	<b>HI</b>	बैटरी
<b>FI</b>	Paristo	<b>TH</b>	แบตเตอรี่
<b>DA</b>	Batteri	<b>SQ</b>	Bateria
<b>ET</b>	Aku/patarei	<b>BS</b>	Baterija
<b>LV</b>	Baterija	<b>ME</b>	Baterija
<b>LT</b>	Akumulatorius	<b>MK</b>	Батерија
<b>RU</b>	Батарея	<b>HY</b>	Սարքսկայն
<b>UK</b>	Акумулятор	<b>VI</b>	Pin

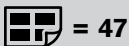

<b>EN</b>	Turning on and off	<b>TR</b>	Açıp Kapatma
<b>DE</b>	Ein- und Ausschalten	<b>EL</b>	Ενεργοποίηση και απενεργοποίηση
<b>ES</b>	Encender y apagar	<b>RO</b>	Pornirea și oprirea
<b>FR</b>	Allumer et éteindre	<b>IS</b>	Kveikja og slökkva
<b>PT</b>	Ligar e desligar	<b>MT</b>	Ixgħel u ifi
<b>IT</b>	Accensione e spegnimento	<b>AR</b>	تشغيل وإيقاف
<b>NL</b>	Aan- en uitschakelen	<b>FA</b>	خاموش و روشن کردن
<b>PL</b>	Włączanie i wyłączenie	<b>YUE</b>	打開和關閉
<b>CS</b>	Zapnutí a vypnutí	<b>CMN</b>	打开和关闭
<b>SK</b>	Zapnutie a vypnutie	<b>JA</b>	オン/オフの切り替え
<b>SL</b>	Vklop in izklop	<b>KO</b>	켜고 끄기
<b>HR</b>	Uključivanje i isključivanje	<b>BG</b>	Включване и изключване
<b>HU</b>	Ki- és bekapcsolás	<b>SR</b>	Uključivanje i isključivanje
<b>SE</b>	Slå på och stänga av	<b>MS</b>	Menghidupkan dan mematikan
<b>NO</b>	Slå på og av	<b>HI</b>	चालू और बंद करना
<b>FI</b>	Käynnistys ja sammutus	<b>TH</b>	การเปิดและปิด
<b>DA</b>	Tænd og sluk	<b>SQ</b>	Ndezja dhe fikja
<b>ET</b>	Sisse- ja väljalülitamine	<b>BS</b>	Uključivanje i isključivanje
<b>LV</b>	Ieslēgšana un izslēgšana	<b>ME</b>	Uključivanje i isključivanje
<b>LT</b>	Ijungimas ir išjungimas	<b>MK</b>	Включвање и исклучвање
<b>RU</b>	Включение и выключение	<b>HY</b>	Միացնելը և անջատելը
<b>UK</b>	Увімкнення та вимкнення	<b>VI</b>	Bật và tắt

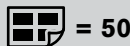

<b>EN</b>	App	<b>TR</b>	Uygulama
<b>DE</b>	App	<b>EL</b>	Εφαρμογή
<b>ES</b>	Aplicación	<b>RO</b>	Aplicatie
<b>FR</b>	Appli	<b>IS</b>	Smáforrit
<b>PT</b>	Aplicação	<b>MT</b>	App
<b>IT</b>	App	<b>AR</b>	تطبيق
<b>NL</b>	App	<b>FA</b>	برنامه
<b>PL</b>	Aplikacja	<b>YUE</b>	應用
<b>CS</b>	Aplikace	<b>CMN</b>	应用
<b>SK</b>	Aplikácia	<b>JA</b>	アプリ
<b>SL</b>	Aplikacija	<b>KO</b>	앱
<b>HR</b>	App	<b>BG</b>	Приложение
<b>HU</b>	App	<b>SR</b>	Aplikacija
<b>SE</b>	App	<b>MS</b>	Aplikasi
<b>NO</b>	App	<b>HI</b>	ऐप
<b>FI</b>	App	<b>TH</b>	แอป
<b>DA</b>	App	<b>SQ</b>	Aplikacion
<b>ET</b>	Rakendus	<b>BS</b>	App
<b>LV</b>	Lietotne	<b>ME</b>	App
<b>LT</b>	Programėlė	<b>MK</b>	Апликација
<b>RU</b>	Приложение	<b>HY</b>	Հավելված
<b>UK</b>	Додаток	<b>VI</b>	Ứng dụng



 = 52

<b>EN</b>	Rocking feature	<b>TR</b>	Sallama özelliği
<b>DE</b>	Schaukelfunktion	<b>EL</b>	Λειτουργία λικνίσματος
<b>ES</b>	Función de balanceo	<b>RO</b>	Funcție de legănare
<b>FR</b>	Fonction basculante	<b>IS</b>	Aðstoð við að rugga
<b>PT</b>	Funcionalidade de embalo	<b>MT</b>	Karatteristika għat-tbennin
<b>IT</b>	Funzione dondolo	<b>AR</b>	خاصية التآرجح
<b>NL</b>	Schommelfunctie	<b>FA</b>	قابلیت حرکت گهواره ای
<b>PL</b>	Funkcja kołysania	<b>YUE</b>	搖擺特徵
<b>CS</b>	Funkce houpaní	<b>CMN</b>	摇摆特征
<b>SK</b>	Funkcia hojdanía	<b>JA</b>	ゆりかご機能
<b>SL</b>	Lastnost zibanja	<b>KO</b>	락킹 기능
<b>HR</b>	Funkcija ljuljanja	<b>BG</b>	Функция за люлеене
<b>HU</b>	Ringató funkció	<b>SR</b>	Funkcija ljuljanja
<b>SE</b>	Vaggningfunktion	<b>MS</b>	Ciri mengayun
<b>NO</b>	Vuggefunksjon	<b>HI</b>	हिलाने-डुलाने की सुविधा
<b>FI</b>	Keinutoiminto	<b>TH</b>	คุณสมบัติการโยก
<b>DA</b>	Vuggefunktion	<b>SQ</b>	Veçoria e lëkundjeve
<b>ET</b>	Kiigefunktsioon	<b>BS</b>	Funkcija ljuljanja
<b>LV</b>	Šūpošanās funkcija	<b>ME</b>	Funkcija ljuljanja
<b>LT</b>	Sūravimo funkcija	<b>MK</b>	Функција за лулање
<b>RU</b>	Функция качания	<b>HY</b>	ճոճման ԼճԺԺ
<b>UK</b>	Функція гойдання	<b>VI</b>	Tính năng đu đưa



 = 53

<b>EN</b>	Hands positioning	<b>TR</b>	Ellerin pozisyonu
<b>DE</b>	Positionierung der Hände	<b>EL</b>	Τοποθέτηση χεριών
<b>ES</b>	Posicionamiento de las manos	<b>RO</b>	Poziționarea mâinilor
<b>FR</b>	Positionnement des mains	<b>IS</b>	Handstaða
<b>PT</b>	Posicionamento das mãos	<b>MT</b>	Pożizzjonar tal-idejn
<b>IT</b>	Posizionamento delle mani	<b>AR</b>	موضع اليدين
<b>NL</b>	Positionering van de handen	<b>FA</b>	موقعیت دستها
<b>PL</b>	Pozycja rąk	<b>YUE</b>	雙手定位
<b>CS</b>	Umístění rukou	<b>CMN</b>	双手定位
<b>SK</b>	Umiestnenie rúk	<b>JA</b>	手の位置
<b>SL</b>	Postavitve rok	<b>KO</b>	손잡이 위치
<b>HR</b>	Pozicioniranje ruku	<b>BG</b>	Разположение на ръцете
<b>HU</b>	Kezek elhelyezése	<b>SR</b>	Pozicioniranje ruku
<b>SE</b>	Positionering av händer	<b>MS</b>	Perletakan tangan
<b>NO</b>	Håndplassering	<b>HI</b>	हैंड पोजिशनिंग
<b>FI</b>	Käsien sijoittaminen	<b>TH</b>	การกำหนดตำแหน่งมือ
<b>DA</b>	Hændernes placering	<b>SQ</b>	Pozicionimi i duarve
<b>ET</b>	Käte asend	<b>BS</b>	Pozicioniranje ruku
<b>LV</b>	Roku pozicionēšana	<b>ME</b>	Pozicioniranje ruku
<b>LT</b>	Rankų padėtis	<b>MK</b>	Положба на раце
<b>RU</b>	Позиционирование рук	<b>HY</b>	Ձեռքերի դիրքավորում
<b>UK</b>	Положення рук	<b>VI</b>	Định vị trí bàn tay



= 54

<b>EN</b>	Smart hill assist	<b>EL</b>	Έξυπνη υποβοήθηση στην ανηφόρα	<b>LV</b>	Viedā virzības kalnā palīdzības sistēma	<b>BS</b>	Pametna asistencija na brdu
<b>DE</b>	Smarte Unterstützung bei hügeligem Gelände	<b>RO</b>	Asistentă inteligentă la deal	<b>LT</b>	Išmanioji pagalba įkalnėje	<b>ME</b>	Pametna asistencija na brdu
<b>ES</b>	Asistencia inteligente para cuestras	<b>IS</b>	Brekkuaðstoð	<b>RU</b>	Смарт-функция для подъема на возвышенности	<b>MK</b>	Помош за блага нагорнина
<b>FR</b>	Assistance intelligente dans les pentes	<b>MT</b>	Assistenza intelligenti għat-tlajja'	<b>UK</b>	Розумна система підтримки на схилах	<b>HY</b>	Սմարթ աջակցութիւն բարձրանալիս
<b>PT</b>	Assistência aos declives inteligente	<b>AR</b>	مساعد الإحاطة الذكي	<b>TR</b>	Akıllı yokuş yardımcısı	<b>VI</b>	Bộ phận hỗ trợ lên xuống dốc thông minh
<b>IT</b>	Assistenza per le salite	<b>FA</b>	کمک هوشمند در سربالایی				
<b>NL</b>	Intelligente ondersteuning op heuvelachtig terrein	<b>YUE</b>	智慧坡道輔助系統				
<b>PL</b>	Inteligentny system wspomagania jazdy pod górę	<b>CMN</b>	智能坡道輔助系統				
<b>CS</b>	Chytrý asistent pro jízdu do kopce	<b>JA</b>	スマート坂道アシスト				
<b>SK</b>	Chytrý asistent pre jazdu do kopca	<b>KO</b>	스마트 언덕 보조				
<b>SL</b>	Pametni pomočnik za klance	<b>BG</b>	Интелигентна помощ при наклон				
<b>HR</b>	Pametna asistencija na brdu	<b>SR</b>	Pametna asistencija na brdu				
<b>HU</b>	Okos visszafutásgátló	<b>MS</b>	Pembantu bukit pintar				
<b>SE</b>	Smart assistans för uppførsbackar	<b>HI</b>	स्मार्ट हिल असिस्ट				
<b>NO</b>	Smart bakkeassistent	<b>TH</b>	ระบบช่วยลงเนินอัจฉริยะ				
<b>FI</b>	Älykäs mäkiavustaja	<b>SQ</b>	Asistent inteligjent për malore				
<b>DA</b>	Smart hjælp i bakket terræn	<b>ET</b>	Nutikas mägise maastiku abi				

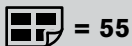

= 55

<b>EN</b>	Uneven surface assist	<b>EL</b>	Υποβοήθηση για ανώμαλες επιφάνειες	<b>DA</b>	Smart hjælp på ujævne overflader	<b>TH</b>	ระบบช่วยบนพื้นผิวที่ไม่สม่ำเสมอ
<b>DE</b>	Smarte Unterstützung bei unebenen Oberflächen	<b>RO</b>	Asistență de suprafață neuniformă	<b>ET</b>	Ebaühtlase pinna läbimisabi	<b>SQ</b>	Asistent për sipërfaqe jo të sheshta
<b>ES</b>	Asistencia para superficies irregulares	<b>IS</b>	Aðstoð á ójöfnu undirlagi	<b>LV</b>	Virzības pa nelīdzenu virsmu palīdzības sistēma	<b>BS</b>	Asistencija na neravnim površinama
<b>FR</b>	Assistance sur les surfaces inégales	<b>MT</b>	Assistenza għal fuq uçuħ mhux lixxi	<b>LT</b>	Pagalba važiuojant ant nelygių dangos	<b>ME</b>	Asistencija na neravnim površinama
<b>PT</b>	Assistência às superficies irregulares	<b>AR</b>	خاصية دعم الحركة على الأسطح غير المستوية	<b>RU</b>	Смарт-функция для работы на неровных поверхностях	<b>MK</b>	Помош за нерамна површина
<b>IT</b>	Assistenza per superfici non uniformi	<b>FA</b>	کمک جهت سطوح ناصاف	<b>UK</b>	Система підтримки на нерівній поверхні	<b>HY</b>	Անհարթ մակերեսի արջակցություն
<b>NL</b>	Ondersteuning voor oneffen oppervlaktes	<b>YUE</b>	凹凸不平表面輔助系統	<b>TR</b>	Düzgün olmayan yüzey yardımcısı	<b>VI</b>	Bộ phận hỗ trợ khi đi trên bề mặt không bằng phẳng
<b>PL</b>	Wspomaganie jazdy po nierównym terenie	<b>CMN</b>	凹凸不平表面輔助系統				
<b>CS</b>	Asistent jízdy na nerovném povrchu	<b>JA</b>	でこぼこ道アシスト				
<b>SK</b>	Asistent jazdy na nerovnom povrchu	<b>KO</b>	평탄하지 않은 표면 보조				
<b>SL</b>	Pametni pomočnik za neravne površine	<b>BG</b>	Помощ при неравни повърхности				
<b>HR</b>	Asistencija na neravnim površinama	<b>SR</b>	Asistencija na neravnim površinama				
<b>HU</b>	Egyenetlenfelület-asszisztens	<b>MS</b>	Pembantu permukaan tidak rata				
<b>SE</b>	Assistans vid ojämn underlag	<b>HI</b>	असमान सतह सहायता				
<b>NO</b>	Ujevne overflate-assistent	<b>FI</b>	Älykäs avustaja epätasaisilla pinnoilla				



 = 56

<b>EN</b>	Folding	<b>TR</b>	Katlama
<b>DE</b>	Faltung	<b>EL</b>	Αναδίπλωση
<b>ES</b>	Plegado	<b>RO</b>	Pliere
<b>FR</b>	Pliant	<b>IS</b>	Brjóta saman
<b>PT</b>	Fecho	<b>MT</b>	Tiwi
<b>IT</b>	Ripiegamento	<b>AR</b>	
<b>NL</b>	Vouwen	<b>FA</b>	
<b>PL</b>	Składanie	<b>YUE</b>	折疊
<b>CS</b>	Skládání	<b>CMN</b>	折疊
<b>SK</b>	Zloženie	<b>JA</b>	折りたたみ
<b>SL</b>	Zlaganje	<b>KO</b>	접기
<b>HR</b>	Preklapanje	<b>BG</b>	Сгъване
<b>HU</b>	Összecsukás	<b>SR</b>	Preklapanje
<b>SE</b>	Ihopfällning	<b>MS</b>	Lipat
<b>NO</b>	Sammenlegging	<b>HI</b>	फोल्डिंग
<b>FI</b>	Kokoon taittaminen	<b>TH</b>	การพับ
<b>DA</b>	Sammenklapning	<b>SQ</b>	Palosja
<b>ET</b>	Kokkuvoltimine	<b>BS</b>	Preklapanje
<b>LV</b>	Salocīšana	<b>ME</b>	Preklapanje
<b>LT</b>	Lankstymas	<b>MK</b>	Склопување
<b>RU</b>	Складывание	<b>HY</b>	Ծախելը
<b>UK</b>	Складання	<b>VI</b>	Gập lại

قابلية للطي  
تا كدرن



 = 58

<b>EN</b>	Two wheel mode	<b>TR</b>	iki tekerlekli mod
<b>DE</b>	Zweirad-Modus	<b>EL</b>	Λειτουργία δύο τροχών
<b>ES</b>	Modo de dos ruedas	<b>RO</b>	Mod cu două roți
<b>FR</b>	Mode deux roues	<b>IS</b>	Stilling fyrir tvö hjól
<b>PT</b>	Modo de duas rodas	<b>MT</b>	Modalità b'żewġ roti
<b>IT</b>	Modalità a due ruote	<b>AR</b>	وضع العجلتين
<b>NL</b>	Tweewiel-modus	<b>FA</b>	حالت دوچرخ
<b>PL</b>	Typ dwukołowy	<b>YUE</b>	兩輪模式
<b>CS</b>	Režim dvou kol	<b>CMN</b>	两轮模式
<b>SK</b>	Dvojkolesový režim	<b>JA</b>	2輪モード
<b>SL</b>	Dvokolesni način	<b>KO</b>	두 휠 모드
<b>HR</b>	Režim rada s dva kotača	<b>BG</b>	Режим с две колела
<b>HU</b>	Kétkerék mód	<b>SR</b>	Režim rada na dva točka
<b>SE</b>	Tvåhjulsläge	<b>MS</b>	Mod dua roda
<b>NO</b>	Tohjulmodus	<b>HI</b>	दो पहिया मोड
<b>FI</b>	Kaksipyöräinen tila	<b>TH</b>	โหมดสองล้อ
<b>DA</b>	Tohjulstilstand	<b>SQ</b>	Modaliteti me dy rrota
<b>ET</b>	Kahe ratta režiim	<b>BS</b>	Režim rada na dva točka
<b>LV</b>	Divu riteņu režīms	<b>ME</b>	Režim rada na dva točka
<b>LT</b>	Dviejų ratų režimas	<b>MK</b>	Режим за две тркала
<b>RU</b>	Двухколесный режим	<b>HY</b>	Երկանիսիվ ռեժիմ
<b>UK</b>	Двоколісний режим	<b>VI</b>	Chế độ hai bánh xe



 = 59

<b>EN</b>	Brake	<b>TR</b>	Fren
<b>DE</b>	Bremse	<b>EL</b>	Φρένα
<b>ES</b>	Freno	<b>RO</b>	Frână
<b>FR</b>	Frein	<b>IS</b>	Bremsa
<b>PT</b>	Bloqueio	<b>MT</b>	Brejġ
<b>IT</b>	Freno	<b>AR</b>	
<b>NL</b>	Rem	<b>FA</b>	
<b>PL</b>	Hamulec	<b>YUE</b>	剎車
<b>CS</b>	Brzda	<b>CMN</b>	刹车
<b>SK</b>	Brzda	<b>JA</b>	ブレーキ
<b>SL</b>	Zavora	<b>KO</b>	브레이크
<b>HR</b>	Kočnica	<b>BG</b>	Спирачка
<b>HU</b>	Fék	<b>SR</b>	Коћница
<b>SE</b>	Broms	<b>MS</b>	Brek
<b>NO</b>	Brems	<b>HI</b>	ब्रेक
<b>FI</b>	Jarru	<b>TH</b>	เบรค
<b>DA</b>	Bremse	<b>SQ</b>	Frenat
<b>ET</b>	Pidur	<b>BS</b>	Коћница
<b>LV</b>	Bremze	<b>ME</b>	Коћница
<b>LT</b>	Stabdys	<b>MK</b>	Сопирачка
<b>RU</b>	Тормоза	<b>HY</b>	Արգելակ
<b>UK</b>	Гальма	<b>VI</b>	Phanh thắng

المكابح  
ترمز



 = 60

<b>EN</b>	Handle bar	<b>TR</b>	Tutma sapı
<b>DE</b>	Schiebegriff	<b>EL</b>	Ράβρος λαβής
<b>ES</b>	Manillar	<b>RO</b>	Mâner
<b>FR</b>	Poignée de poussée	<b>IS</b>	Handfang
<b>PT</b>	Guiador	<b>MT</b>	Handle bar
<b>IT</b>	Manubrio	<b>AR</b>	عارضضة المقبض
<b>NL</b>	Duwstang	<b>FA</b>	میله دسته
<b>PL</b>	Uchwyt	<b>YUE</b>	把手
<b>CS</b>	Madlo	<b>CMN</b>	把手
<b>SK</b>	Rukoväť	<b>JA</b>	ハンドルバー
<b>SL</b>	Ročaj	<b>KO</b>	핸들 바
<b>HR</b>	Ručice	<b>BG</b>	Кормило
<b>HU</b>	Tolókar	<b>SR</b>	Ručke
<b>SE</b>	Handtag	<b>MS</b>	Bar remengang
<b>NO</b>	Håndtak	<b>HI</b>	हैंडल बार
<b>FI</b>	Työntökahva	<b>TH</b>	ด้ามจับ
<b>DA</b>	Styr	<b>SQ</b>	Shufra e dorezës
<b>ET</b>	Sang	<b>BS</b>	Ručice
<b>LV</b>	Rokturis	<b>ME</b>	Ručke
<b>LT</b>	Rankena	<b>MK</b>	Рачка
<b>RU</b>	Рукоятка	<b>HY</b>	Վարալվարման բռնակ
<b>UK</b>	Рукоятка	<b>VI</b>	Tay cầm



= 60

<b>EN</b> Seat direction	<b>TR</b> Koltuk yönü
<b>DE</b> Sitzrichtung	<b>EL</b> Κατεύθυνση καθίσματος
<b>ES</b> Dirección de la silla	<b>RO</b> Direcție scaun
<b>FR</b> Sens du siège	<b>IS</b> Sætisstefna
<b>PT</b> Orientação do assento	<b>MT</b> Direzzjoni tas-sit
<b>IT</b> Direzione di seduta	<b>AR</b> اتجاه المقعد
<b>NL</b> Zitrichting	<b>FA</b> جهت صندلی
<b>PL</b> Kierunek siedzenia	<b>YUE</b> 座椅方向
<b>CS</b> Směr sedadla	<b>CMN</b> 座椅方向
<b>SK</b> Smer sedadla	<b>JA</b> シートの方向
<b>SL</b> Smer sedeža	<b>KO</b> 좌석 방향
<b>HR</b> Smjer sjedala	<b>BG</b> Посока на седалката
<b>HU</b> Ülészirány	<b>SR</b> Smer sedišta
<b>SE</b> Sitsriktning	<b>MS</b> Arah kerusi
<b>NO</b> Seteretning	<b>HI</b> सीट दिशा
<b>FI</b> Istumasuunta	<b>TH</b> ทิศทางที่นั่ง
<b>DA</b> Sæderetning	<b>SQ</b> Drejtimi i ndenjësës
<b>ET</b> Istme suund	<b>BS</b> Smjer sjedišta
<b>LV</b> Sēdekļa virziens	<b>ME</b> Smjer sjedišta
<b>LT</b> Kėdutės kryptis	<b>MK</b> Правец на седиште
<b>RU</b> Направление сиденья	<b>HY</b> Նստատեղի ուղղություն
<b>UK</b> Напрямок сидіння	<b>VI</b> Hướng ghế ngồi



= 61

<b>EN</b> Backrest	<b>TR</b> Arkalık
<b>DE</b> Rückenlehne	<b>EL</b> Πλάτη
<b>ES</b> Respaldo	<b>RO</b> Spătar
<b>FR</b> Dossier	<b>IS</b> Bak
<b>PT</b> Encosto de costas	<b>MT</b> Serf id-dahar
<b>IT</b> Schienale	<b>AR</b> مسند الظهر
<b>NL</b> Rugleuning	<b>FA</b> پشتی
<b>PL</b> Oparcie	<b>YUE</b> 靠背
<b>CS</b> Opěradlo	<b>CMN</b> 靠背
<b>SK</b> Operadlo	<b>JA</b> 背もたれ
<b>SL</b> Naslonjalo	<b>KO</b> 등받이
<b>HR</b> Naslon	<b>BG</b> Облегалка
<b>HU</b> Háttámla	<b>SR</b> Naslon
<b>SE</b> Ryggstöd	<b>MS</b> Penyangar belakang
<b>NO</b> Rygglene	<b>HI</b> बैकरेस्ट
<b>FI</b> Selkänoja	<b>TH</b> พนักพิง
<b>DA</b> Ryglæn	<b>SQ</b> Mbështetësja e shpinës
<b>ET</b> Seljatugi	<b>BS</b> Naslon
<b>LV</b> Atzveltne	<b>ME</b> Naslon
<b>LT</b> Nugaros atlošas	<b>MK</b> Наслон за грб
<b>RU</b> Спинка	<b>HY</b> Թիվսակ
<b>UK</b> Спинка	<b>VI</b> Phấn tựa lưng



 = 61

<b>EN</b>	Legrest	<b>TR</b>	Bacac desteği
<b>DE</b>	Beinstütze	<b>EL</b>	Στήριγμα ποδιών
<b>ES</b>	Reposapiés	<b>RO</b>	Support picior
<b>FR</b>	Repose-pieds	<b>IS</b>	Fótahvíla
<b>PT</b>	Apoio de pernas	<b>MT</b>	Serħ is-saqajn
<b>IT</b>	Poggiagambe	<b>AR</b>	ميمسّد المساق
<b>NL</b>	Beensteun	<b>FA</b>	جاپایی
<b>PL</b>	Podnózek	<b>YUE</b>	腿托
<b>CS</b>	Opěrka nohou	<b>CMN</b>	腿托
<b>SK</b>	Opierka nôh	<b>JA</b>	足のせ
<b>SL</b>	Naslon za noge	<b>KO</b>	다리받이
<b>HR</b>	Naslon za noge	<b>BG</b>	Подложка за крака
<b>HU</b>	Lábtartó	<b>SR</b>	Naslon za noge
<b>SE</b>	Benstöd	<b>MS</b>	Tempat letak kaki
<b>NO</b>	Benstøtte	<b>HI</b>	लेगरेस्ट
<b>FI</b>	Jalkatuki	<b>TH</b>	ที่วางขา
<b>DA</b>	Benstøtte	<b>SQ</b>	Mbështetësja e këmbëve
<b>ET</b>	Jalatugi	<b>BS</b>	Naslon za noge
<b>LV</b>	Kāju balsts	<b>ME</b>	Naslon za noge
<b>LT</b>	Kojų atrama	<b>MK</b>	Наслон за носе
<b>RU</b>	Подставка для ног	<b>HY</b>	Ուղեքրի հեղման կտն
<b>UK</b>	Опора для ніг	<b>VI</b>	Phàn tựa chân



 = 62

<b>EN</b>	Bumper bar	<b>TR</b>	Tampon çubuğu
<b>DE</b>	Schutzbügel	<b>EL</b>	Μπάρα διάταξης προστασίας
<b>ES</b>	Barra de seguridad	<b>RO</b>	Bară de protecție
<b>FR</b>	Barre de protection	<b>IS</b>	Þverbiti
<b>PT</b>	Barra de segurança	<b>MT</b>	Strixxa tal-bumper
<b>IT</b>	Barra paraurti	<b>AR</b>	عازضة ممتص الصدمات
<b>NL</b>	Veiligheidsbeugel	<b>FA</b>	میله ضربهگیر
<b>PL</b>	Pałak zabezpieczający	<b>YUE</b>	保險杠
<b>CS</b>	Dětské madlo	<b>CMN</b>	保險杠
<b>SK</b>	Detská rúčka	<b>JA</b>	バンパーバー
<b>SL</b>	Varnostni lok	<b>KO</b>	범퍼 바
<b>HR</b>	Štitnik	<b>BG</b>	Броня
<b>HU</b>	Karfa	<b>SR</b>	Štitnik
<b>SE</b>	Stötfångare	<b>MS</b>	Bar bumper
<b>NO</b>	Fender	<b>HI</b>	बम्पर बार
<b>FI</b>	Suojakaari	<b>TH</b>	แบริงกันชน
<b>DA</b>	Sikkerhedsbøjle	<b>SQ</b>	Shufra e parakolpiti
<b>ET</b>	Turvakaar	<b>BS</b>	Štitnik
<b>LV</b>	Aizsarglōks	<b>ME</b>	Štitnik
<b>LT</b>	Amortizatoriaus strypas	<b>MK</b>	Одбојник
<b>RU</b>	Поручень	<b>HY</b>	Թափարգել
<b>UK</b>	Обмежувальний поручень	<b>VI</b>	Thanh chống va đập



 = 62

**EN** Harness  
**DE** Gurtsystem  
**ES** Arnés  
**FR** Harnais  
**PT** Arnês  
**IT** Imbracatura  
**NL** Harnas  
**PL** Szelki  
**CS** Popruh  
**SK** Popruh  
**SL** Varnostni pas  
**HR** Sustav vezivanja  
**HU** Biztonsági öv  
**SE** Sele  
**NO** Beltesystem  
**FI** Vyöjärjestelmä  
**DA** Selesystem  
**ET** Turvarihmad  
**LV** Drošības josta  
**LT** Diržai  
**RU** Ремни безопасности  
**UK** Ремінь

**TR** Emniyet kemeri  
**EL** Συγκράτηση  
**RO** Centură  
**IS** Beisli  
**MT** Ċinga tas-sigurtà  
**AR** طقم الشد  
**FA** سیستم مهار  
**YUE** 安全帶  
**CMN** 安全带  
**JA** 安全ベルト  
**KO** 하네스  
**BG** Сбруя  
**SR** Sistem vezivanja  
**MS** Abah-abah  
**HI** कवच  
**TH** ระบบสายรัด  
**SQ** Pajimet  
**BS** Sistem vezivanja  
**ME** Sistem vezivanja  
**MK** Сигурносен каиш  
**HY** Անրազոսիչ  
**VI** Dây an toàn



 = 65

**EN** Sun canopy  
**DE** Sonnenverdeck  
**ES** Capota para el sol  
**FR** Pare-soleil  
**PT** Capota solar  
**IT** Parasole  
**NL** Zonnekap  
**PL** Oslona przeciwsłoneczna  
**CS** Stříška proti slunci  
**SK** Strieška proti slnku  
**SL** Senčnik za zaščito pred soncem  
**HR** Tenda za sunce  
**HU** Kupola  
**SE** Solsufflett  
**NO** Solskjerm  
**FI** Aurinkokatos  
**DA** Solkaleche  
**ET** Päikesevari  
**LV** Saules aizsegs  
**LT** Stogelis nuo saulės  
**RU** Солнцезащитный козырек  
**UK** Тент від сонця

**TR** Güneş başlığı  
**EL** Κουκούλα για τον ήλιο  
**RO** Copertină  
**IS** Sólartjald  
**MT** Kopertura mix-xemx  
**AR** مظلة الشمس  
**FA** سایبان  
**YUE** 遮陽蓬  
**CMN** 遮阳蓬  
**JA** 日よけ力バー  
**KO** 선 캐노피  
**BG** Тента  
**SR** Tenda za sunce  
**MS** Kanopi matahari  
**HI** छुप छतरी  
**TH** หลังคาบังแดด  
**SQ** Strea për diellin  
**BS** Tenda za sunce  
**ME** Tenda za sunce  
**MK** Стрепа за сонце  
**HY** Արևապաշտպան ծածկ  
**VI** Mái che nắng



 = 66

<b>EN</b> Swivel locks	<b>TR</b> Tekerlek kilidi
<b>DE</b> Schwenkradsperre	<b>EL</b> Περιστρεφόμενες κλειδαριές
<b>ES</b> Bloqueos de dirección	<b>RO</b> Încuietori pivotante
<b>FR</b> Verrous pivotants	<b>IS</b> Snúningslásar
<b>PT</b> Bloqueios de rotação	<b>MT</b> Lokks li jduru
<b>IT</b> Blocchi girevoli	<b>AR</b> أقفال دوران العجلات
<b>NL</b> Zwenkvergrendeling	<b>FA</b> قفل‌های نوسان
<b>PL</b> Blokada obrotu	<b>YUE</b> 旋轉鎖
<b>CS</b> Aretační zámky	<b>CMN</b> 旋转锁
<b>SK</b> Aretačné zámky	<b>JA</b> 回転ロック
<b>SL</b> Blokada vrtenja	<b>KO</b> 회전 잠금장치
<b>HR</b> Zaključavanje okretanja	<b>BG</b> Завъртащи се ключалки
<b>HU</b> Beállás-zár	<b>SR</b> Zakretni mehanizmi
<b>SE</b> Vridlås	<b>MS</b> Kunci ayun
<b>NO</b> Svingelåser	<b>HI</b> कुंडा ताले
<b>FI</b> Kääntölukko	<b>TH</b> ตัวล็อกแอมมิซึน
<b>DA</b> Drejelås	<b>SQ</b> Kucja e rrotave
<b>ET</b> Pöördlukustus	<b>BS</b> Zakretni mehanizmi
<b>LV</b> Rotācijas bloķētāji	<b>ME</b> Zakretni mehanizmi
<b>LT</b> Šarnyriniai fiksatoriai	<b>MK</b> Заклучување на тркалата
<b>RU</b> Блокировки вращения	<b>HY</b> Պտտվող կողպիչներ
<b>UK</b> Замок шарніра	<b>VI</b> Khóa xoay



 = 67

<b>EN</b> Removing the wheels	<b>TR</b> Tekerlekleri çıkarma
<b>DE</b> Entfernen der Räder	<b>EL</b> Αφαίρεση των τροχών
<b>ES</b> Quitar las ruedas	<b>RO</b> Îndepărtarea roților
<b>FR</b> Retrait des roues	<b>IS</b> Fjarlægja hjól
<b>PT</b> Remover as rodas	<b>MT</b> Tneħhija tar-roti
<b>IT</b> Rimozione delle ruote	<b>AR</b> فك العجلات
<b>NL</b> De wielen verwijderen	<b>FA</b> باز کردن چرخها
<b>PL</b> Zdejmowanie kółek	<b>YUE</b> 拆卸車輪
<b>CS</b> Odstranění koleček	<b>CMN</b> 拆卸车轮
<b>SK</b> Odstránenie koliesok	<b>JA</b> 車輪の取り外し
<b>SL</b> Odstranjevanje koles	<b>KO</b> 휠 제거
<b>HR</b> Uklanjanje kotača	<b>BG</b> Демонтиране на колелата
<b>HU</b> Kerekeltávolítás	<b>SR</b> Uklanjanje točkova
<b>SE</b> Ta bort hjulen	<b>MS</b> Menanggalkan roda
<b>NO</b> Fjerne hjulene	<b>HI</b> पहियों को हटाना
<b>FI</b> Pyörien poisto	<b>TH</b> การถอดล้อ
<b>DA</b> Fjernelse af hjulene	<b>SQ</b> Heqja e rrotave
<b>ET</b> Rataste eemaldamine	<b>BS</b> Uklanjanje točkova
<b>LV</b> Riteņu atvienošana	<b>ME</b> Uklanjanje točkova
<b>LT</b> Ratų nuėmimas	<b>MK</b> Отстранување на тркалата
<b>RU</b> Снятие колес	<b>HY</b> Անխլւեղը հաւաքելը
<b>UK</b> Зняття коліс	<b>VI</b> Tháo bánh xe



 = 68

**EN** Rain cover  
**DE** Regenverdeck  
**ES** Funda para la lluvia  
**FR** Housse de pluie  
**PT** Capa de chuva  
**IT** Parapioggia  
**NL** Regenhoes  
**PL** Osłona od deszczu  
**CS** Pláštěnka  
**SK** Kryt proti dažďu  
**SL** Dežna prevleka  
**HR** Pokrivač za kišu  
**HU** Esővédő  
**SE** Regnskydd  
**NO** Kalesje  
**FI** Sadesuoja  
**DA** Regnslag  
**ET** Vihmakate  
**LV** Pretlietus pārvalks  
**LT** Uždangalas nuo lietaus  
**RU** Дождевик  
**UK** Дошовик

**TR** Yağmurluk  
**EL** Καλύπτρα βροχής  
**RO** Prelată de ploaie  
**IS** Regn yfirbreiðsla  
**MT** Għata mix-xita  
**AR** غطاء المطر  
**FA** روکش باران  
**YUE** 防雨罩  
**CMN** 防雨罩  
**JA** 雨よけ  
**KO** 레인커버  
**BG** Дъждобран  
**SR** Pokrivač za kišu  
**MS** Pelindung hujan  
**HI** रैन कवर  
**TH** ฝ้ายคลุมกันฝน  
**SQ** Mbulesë për shiun  
**BS** Pokrivač za kišu  
**ME** Pokrivač za kišu  
**MK** Прекривка за дожд  
**HY** Անձրևապաշտպան օտձկ  
**VI** Tấm che mưa



 = 68

**EN** Infant Car Seat  
**DE** Babyschale  
**ES** Silla infantil para coche  
**FR** Siège auto pour enfant  
**PT** Cadeira auto infantil  
**IT** Seggiolino per auto  
**NL** Autostoeltje  
**PL** Fotelik dla niemowlaka  
**CS** Vajíčko  
**SK** Autosedačka pre dojčatá  
**SL** Avtosedež za dojenčke  
**HR** Autosjedalica za bebe  
**HU** Gyermekek autósülés  
**SE** Bilbarnstol  
**NO** Barnebilsete  
**FI** Lasten istuin  
**DA** Autostol  
**ET** Imiku turvatool  
**LV** Zīdaiņu sēdekļis  
**LT** Automobiline naujagimio kėdutė  
**RU** Детское автокресло  
**UK** Автокрісло для немовлят

**TR** Bebek Araba Koltuğu  
**EL** Παιδικό κάθισμα αυτοκινήτου  
**RO** Scaunul auto pentru infant  
**IS** Smábarnabílstóll  
**MT** Sit tal-Karozza tat-Tfal  
**AR** مقعد سيارة للرضع  
**FA** صندلی خودرو برای نوزاد  
**YUE** 嬰兒汽車座椅  
**CMN** 婴儿汽车座椅  
**JA** 幼児用カーシート  
**KO** 유아용 카시트  
**BG** Бебешка седалка за автомобил  
**SR** Auto sedište za bebe  
**MS** Kerusi Keselamatan Bayi  
**HI** शिशु कार सीट  
**TH** คาร์ซีทสำหรับเด็กทารก  
**SQ** Sexholino  
**BS** Auto sjedište za bebe  
**ME** Auto sjedište za bebe  
**MK** Детско седиште за автомобил  
**HY** Ավտոմոբիլային ստոլաշտոլ  
**VI** Ghế xe dành cho trẻ sơ sinh



<b>EN</b>	Carry Cot	<b>TR</b>	Portbebe
<b>DE</b>	Kinderwagenaufsatz	<b>EL</b>	Πορτ-μπεμπέ
<b>ES</b>	Capazo	<b>RO</b>	Landou portabil
<b>FR</b>	Navelle bébé	<b>IS</b>	Burðarrúm
<b>PT</b>	Alcofa	<b>MT</b>	Carry Cot
<b>IT</b>	Culla portatile	<b>AR</b>	سرير محمول
<b>NL</b>	Zitbak	<b>FA</b>	ساک حمل نوزاد
<b>PL</b>	Gondola wózka dziecięcego	<b>YUE</b>	便攜嬰兒床
<b>CS</b>	Hluboká korba	<b>CMN</b>	便携嬰兒床
<b>SK</b>	Korba na prenášanie	<b>JA</b>	持ち運びベッド
<b>SL</b>	Nosilna košara	<b>KO</b>	캐리콧
<b>HR</b>	Ležaljka za prenošenje	<b>BG</b>	Легло за носене
<b>HU</b>	Mózeskosár	<b>SR</b>	Dodatak za kolica
<b>SE</b>	Barnvagnslift	<b>MS</b>	Katil Bayi Bimbit
<b>NO</b>	Babybag	<b>HI</b>	कैरी कॉट
<b>FI</b>	Kantolaukku	<b>TH</b>	ตะกร้าที่นอนเด็ก
<b>DA</b>	Babylift	<b>SQ</b>	Djep
<b>ET</b>	Vankrikorv	<b>BS</b>	Dodatak za kolica
<b>LV</b>	Bērnu gultiņa	<b>ME</b>	Dodatak za kolica
<b>LT</b>	Nešiojamasis lopšys	<b>MK</b>	Кошница за носење
<b>RU</b>	Переносная люлька	<b>HY</b>	Սանկալակն շարժական մահճալակ
<b>UK</b>	Переносне дитяче ліжечко	<b>VI</b>	Nôi xách tay

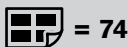

<b>EN</b>	Removing the fabric	<b>TR</b>	Kilifi çıkarma
<b>DE</b>	Entfernen des Bezuges	<b>EL</b>	Αφαίρεση του υφάσματος
<b>ES</b>	Quitar la tela	<b>RO</b>	Îndepărtarea țesăturii
<b>FR</b>	Retrait du tissu	<b>IS</b>	Fjarlægja efni
<b>PT</b>	Remover o tecido	<b>MT</b>	Tnehhija tad-drapp
<b>IT</b>	Rimozione del tessuto	<b>AR</b>	فك القماش
<b>NL</b>	De stof verwijderen	<b>FA</b>	برداشتن پارچه
<b>PL</b>	Zdejbowanie pokrycia	<b>YUE</b>	拆除罩布
<b>CS</b>	Odstranění látky	<b>CMN</b>	拆除罩布
<b>SK</b>	Odstránenie látky	<b>JA</b>	カバーの取り外し
<b>SL</b>	Odstranjevanje blaga	<b>KO</b>	페브릭 제거
<b>HR</b>	Uklanjanje tkanine	<b>BG</b>	Демонтиране на плата
<b>HU</b>	Huzat eltávolítása	<b>SR</b>	Uklanjanje tkanine
<b>SE</b>	Ta bort tyget	<b>MS</b>	Menanggalkan fabrik
<b>NO</b>	Fjerne stoffet	<b>HI</b>	कपड़ा हटाना
<b>FI</b>	Kankaan poisto	<b>TH</b>	การถอดผ้า
<b>DA</b>	Fjernelse af stoffet	<b>SQ</b>	Heqja e copës
<b>ET</b>	Kanga eemaldamine	<b>BS</b>	Uklanjanje tkanine
<b>LV</b>	Pārklājuma atvienošana	<b>ME</b>	Uklanjanje tkanine
<b>LT</b>	Audinio nuėmimas	<b>MK</b>	Отстранување на навлакмата
<b>RU</b>	Снятие ткани	<b>HY</b>	Գործվածքը հանելը
<b>UK</b>	Зняття матерії	<b>VI</b>	Tháo phần vải bọc

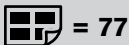

<b>EN</b>	Troubleshooting	<b>TR</b>	Sorun Giderme
<b>DE</b>	Fehlerbehebung	<b>EL</b>	Αντιμετώπιση προβλημάτων
<b>ES</b>	Resolución de problemas	<b>RO</b>	Depanare
<b>FR</b>	Dépannage	<b>IS</b>	Úrræðaleit
<b>PT</b>	Resolução de problemas	<b>MT</b>	Solvien ta' problemi
<b>IT</b>	Risoluzione dei problemi	<b>AR</b>	استكشاف الأخطاء وإصلاحها
<b>NL</b>	Probleemoplossing	<b>FA</b>	عیب‌یابی
<b>PL</b>	Rozwiązywanie problemów	<b>YUE</b>	故障排除
<b>CS</b>	Řešení problémů	<b>CMN</b>	故障排除
<b>SK</b>	Řešenie problémov	<b>JA</b>	トラブルシューティング
<b>SL</b>	Odpravljanje težav	<b>KO</b>	문제 해결
<b>HR</b>	Rješavanje problema	<b>BG</b>	Отстраняване на проблеми
<b>HU</b>	Hibaelhárítás	<b>SR</b>	Rešavanje problema
<b>SE</b>	Felsökning	<b>MS</b>	Menyelesai masalah
<b>NO</b>	Feilsøking	<b>HI</b>	समस्या निवारण
<b>FI</b>	Virheiden poisto	<b>TH</b>	การแก้ไขปัญหา
<b>DA</b>	Problemløsning	<b>SQ</b>	Zgjidhja e problemeve
<b>ET</b>	Tõrkeotsing	<b>BS</b>	Rješavanje problema
<b>LV</b>	Problēmu novēršana	<b>ME</b>	Rješavanje problema
<b>LT</b>	Gedimų šalinimas	<b>MK</b>	Решавање проблеми
<b>RU</b>	Устранение неисправностей	<b>HY</b>	Անսարքույունների շտկում
<b>UK</b>	Усунення несправностей	<b>VI</b>	Khắc phục sự cố

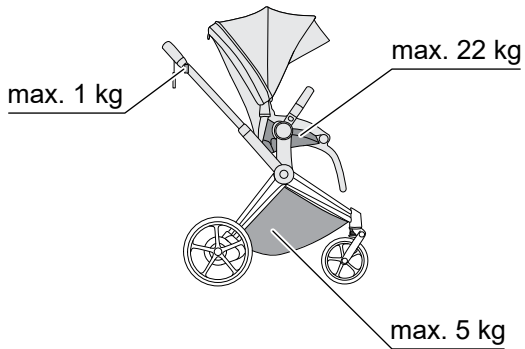

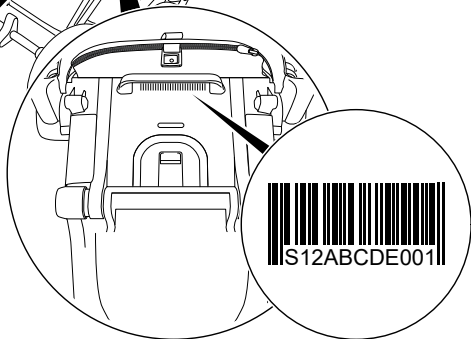
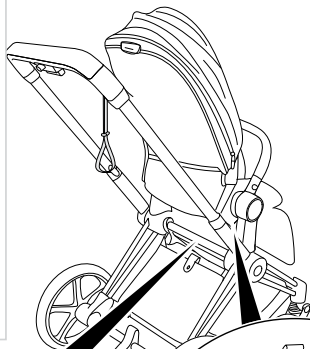

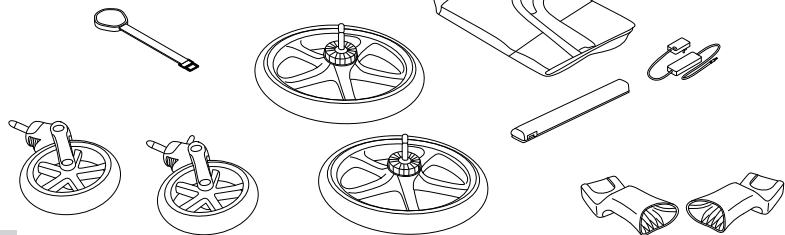
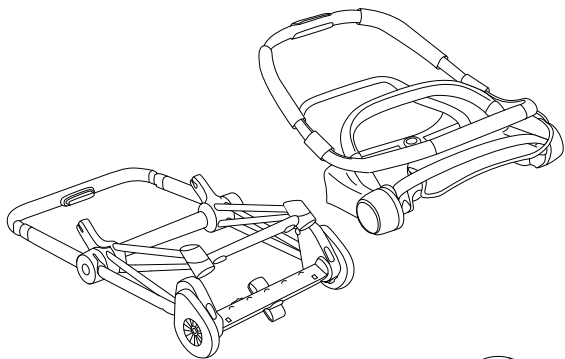

1

21

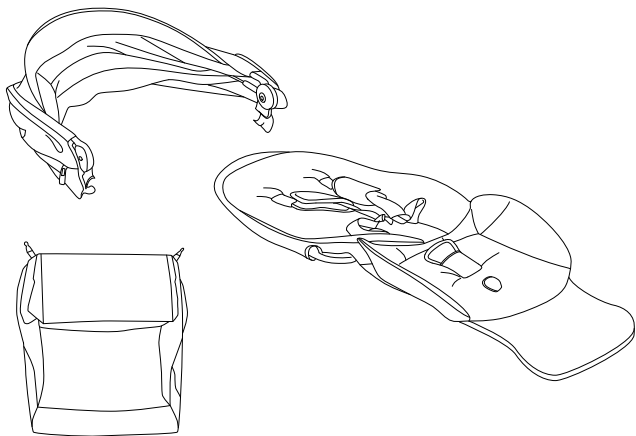

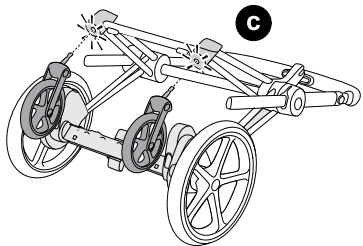
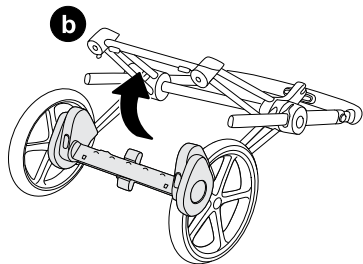
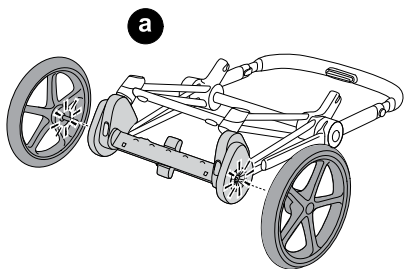

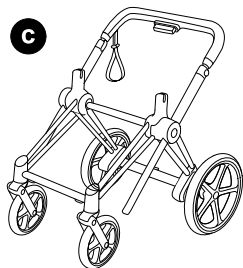
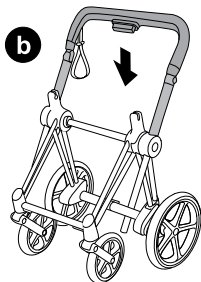
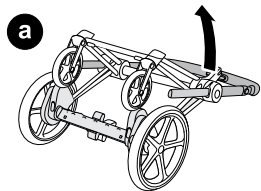

4

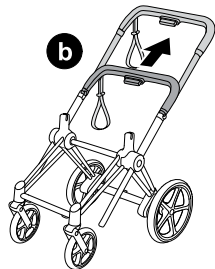
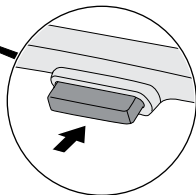
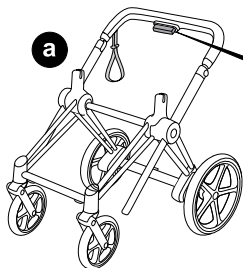

5

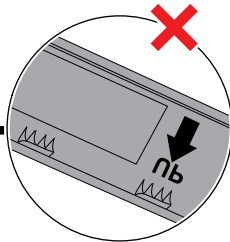
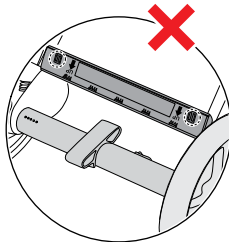
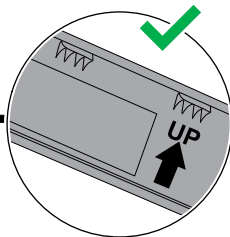
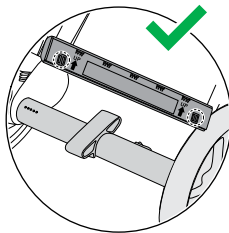
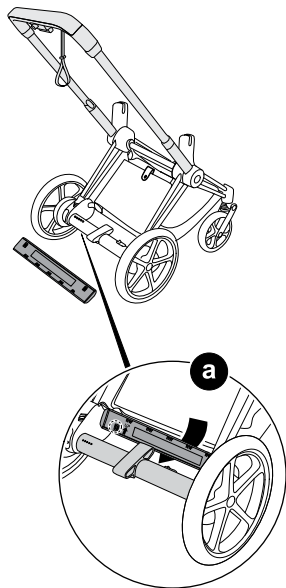

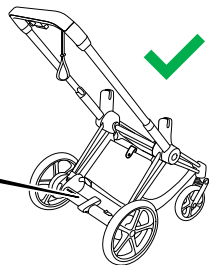
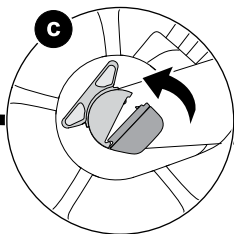
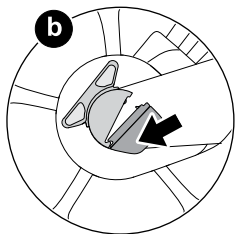

7

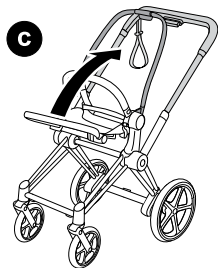
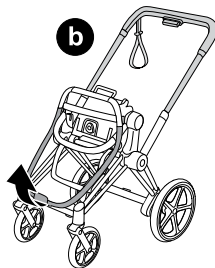
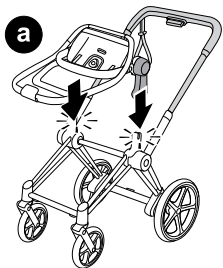

8

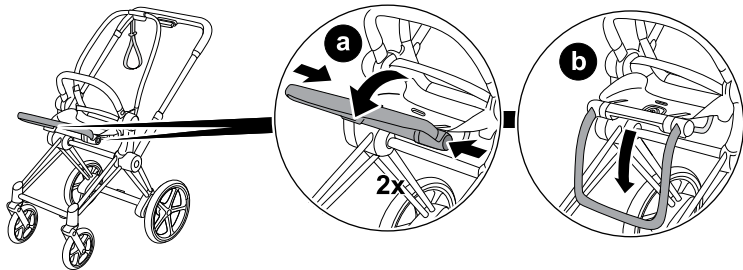

9



10

27

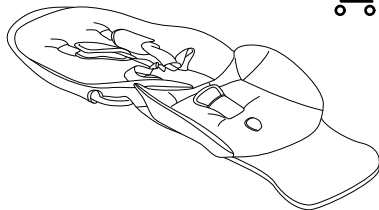
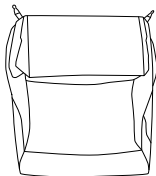
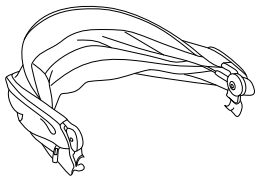

1

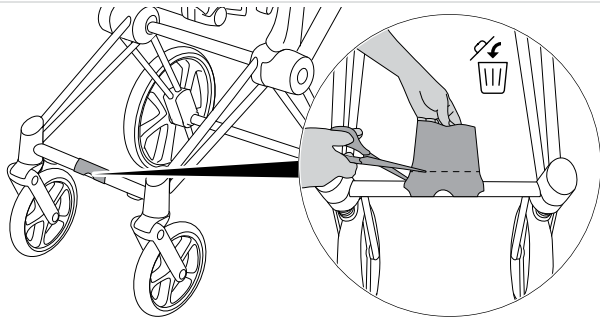

28

2

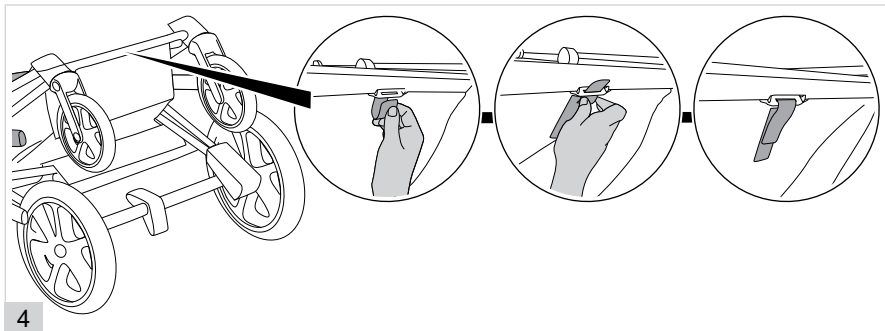
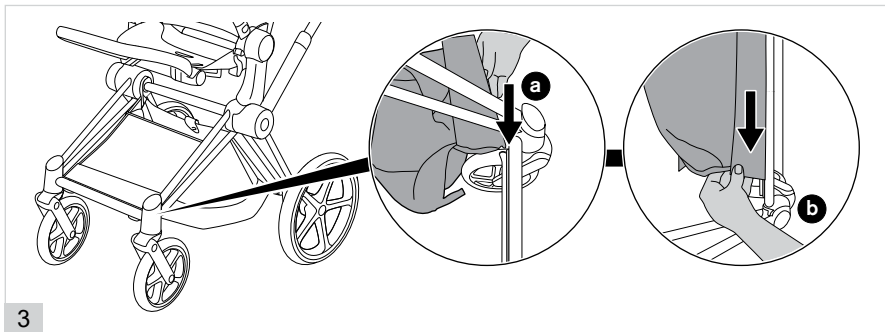

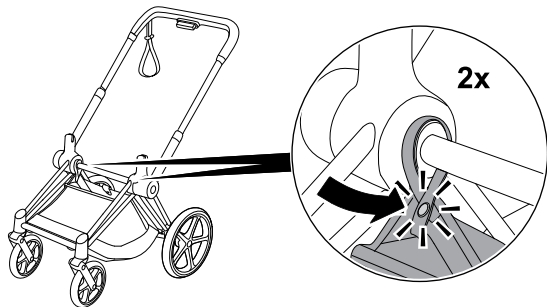

5

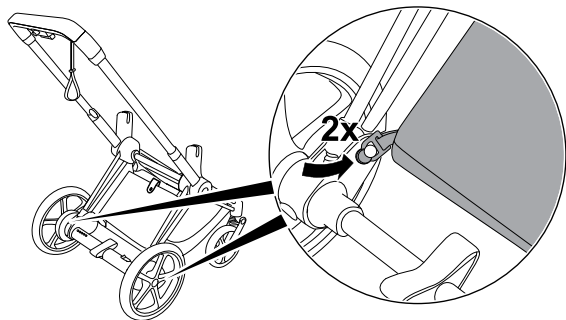

6

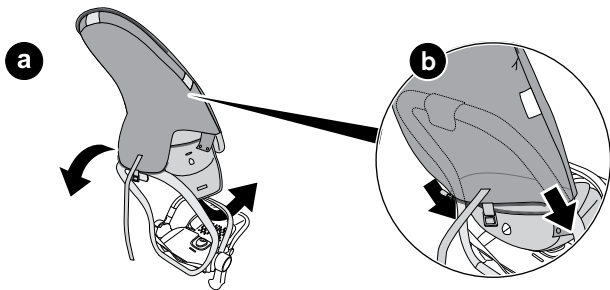

7

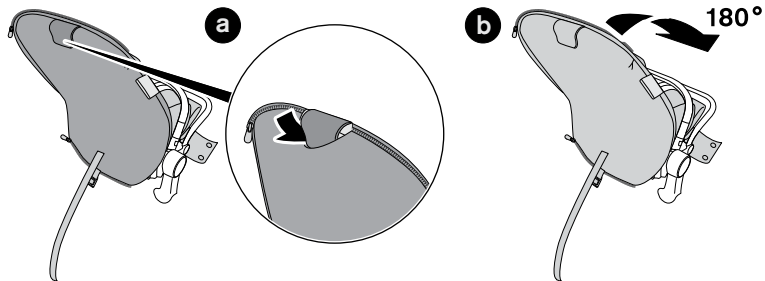

8

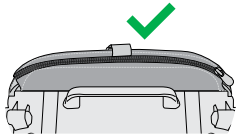
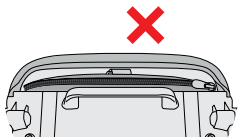
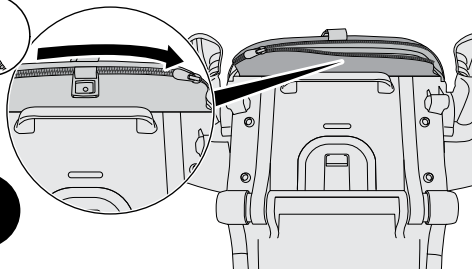

9

**a**

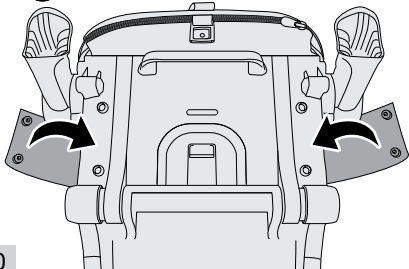

**b**

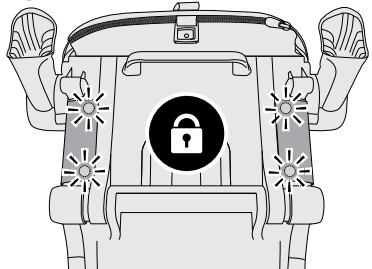

10

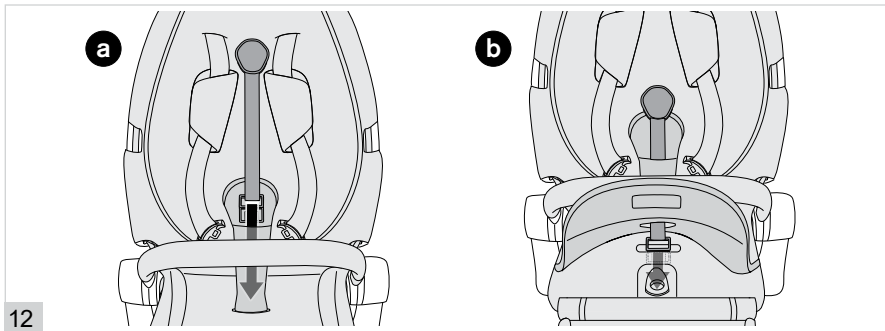
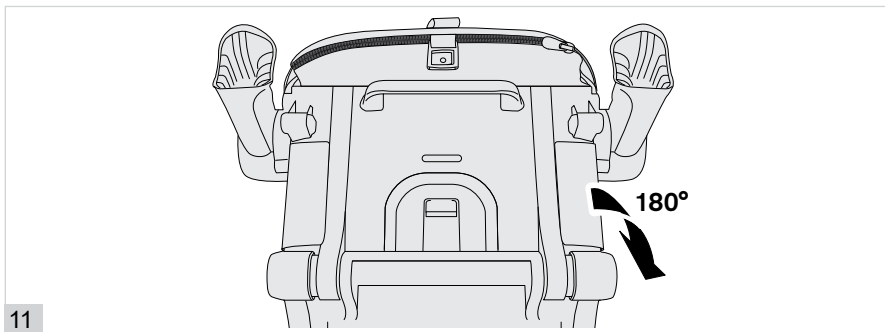



**a**

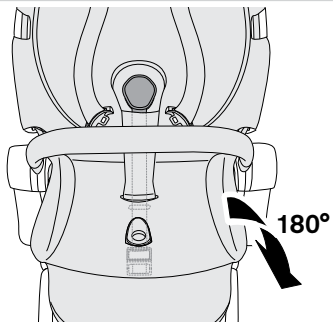

13

**b**

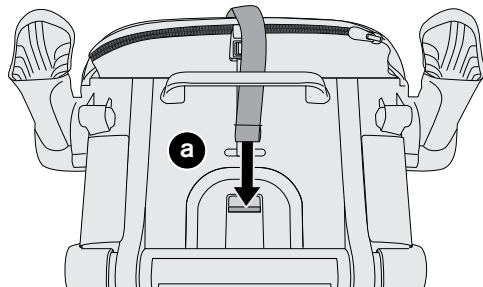
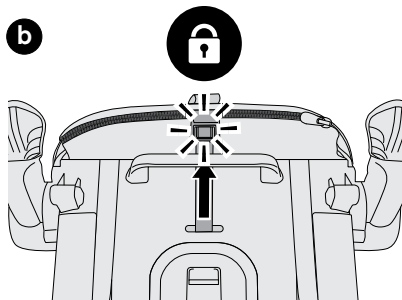

**a**

34

14

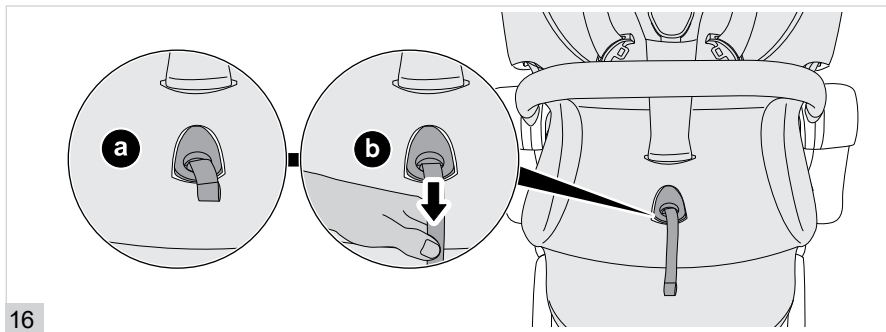
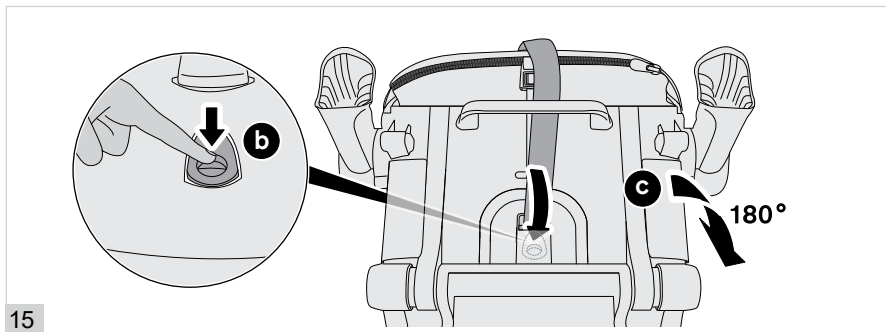

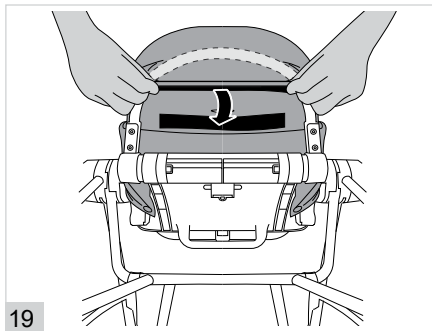
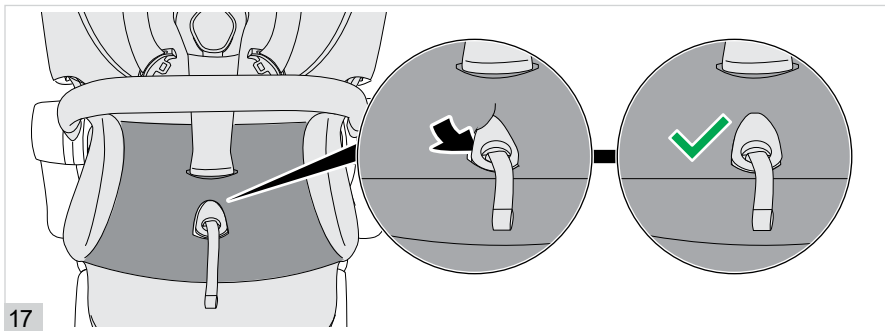

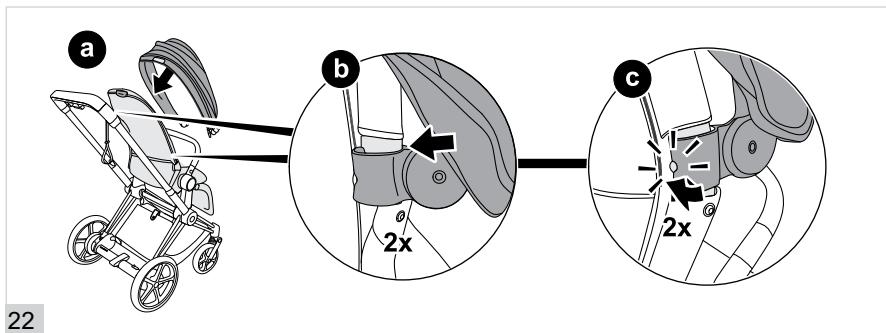
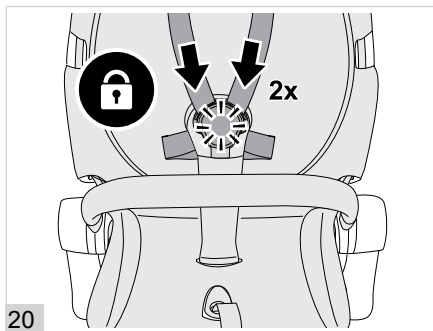

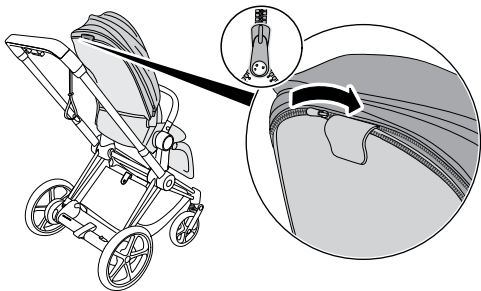

23

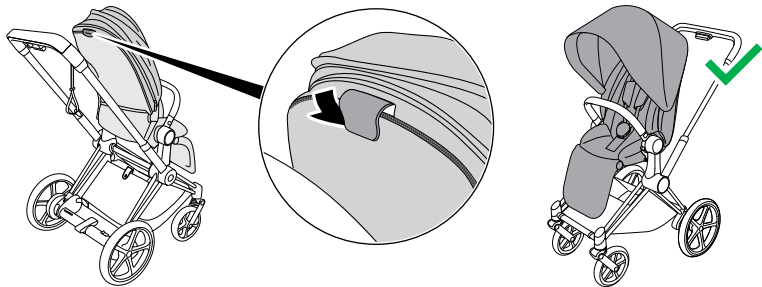

38

24

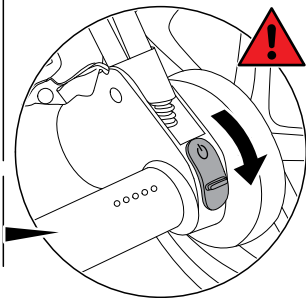
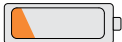
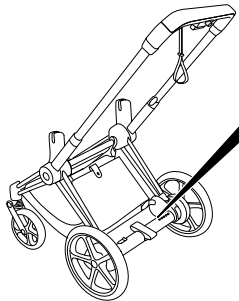

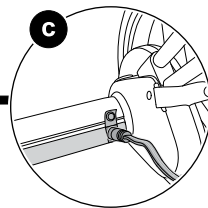
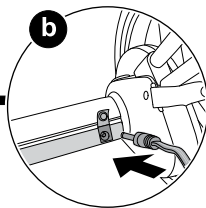
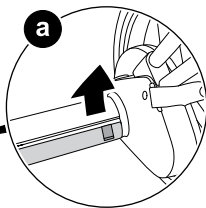
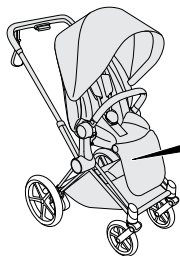

2



100 - 240 V  
50/60Hz 1,3A

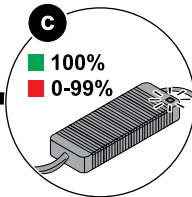
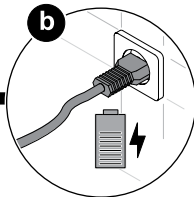
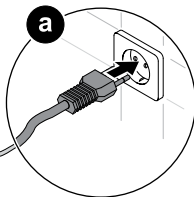

40

3

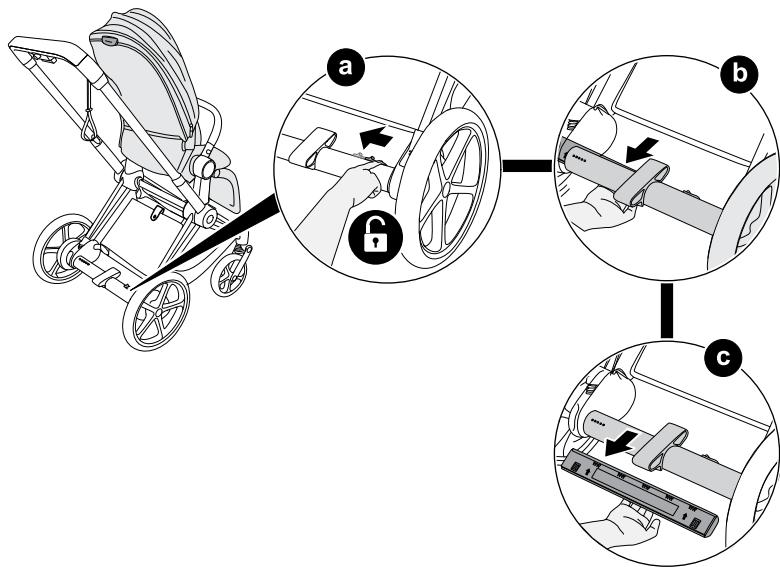

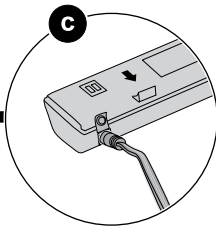
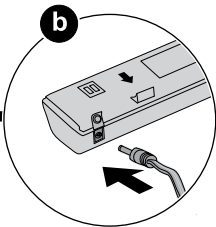
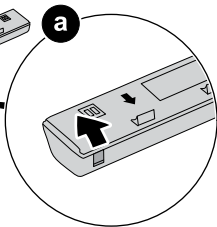
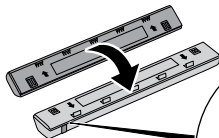

5

100 - 240 V  
50/60Hz 1,3A

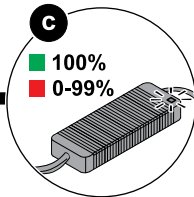
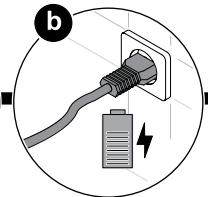
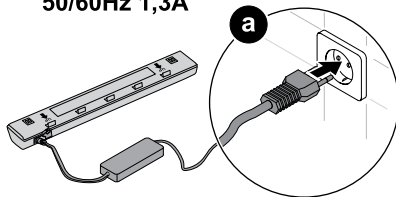

6

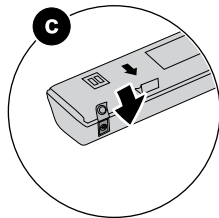
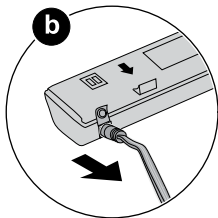
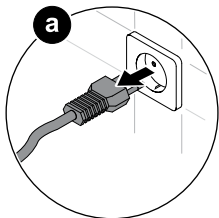

7

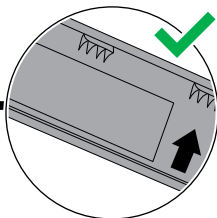
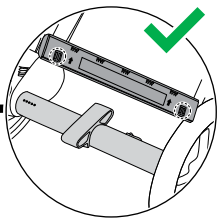
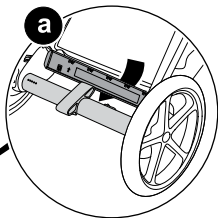
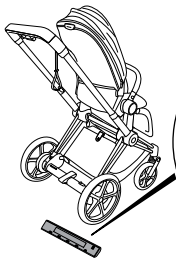

8

43

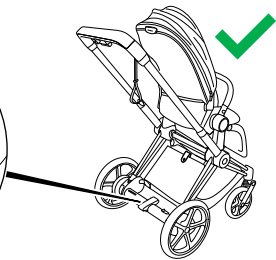
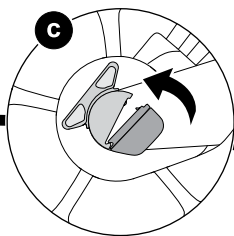
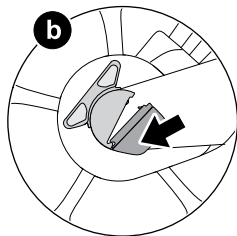

9

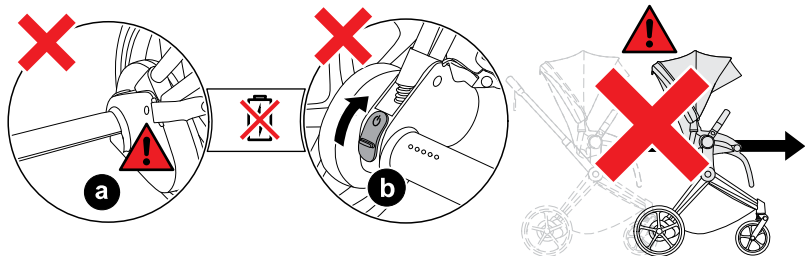
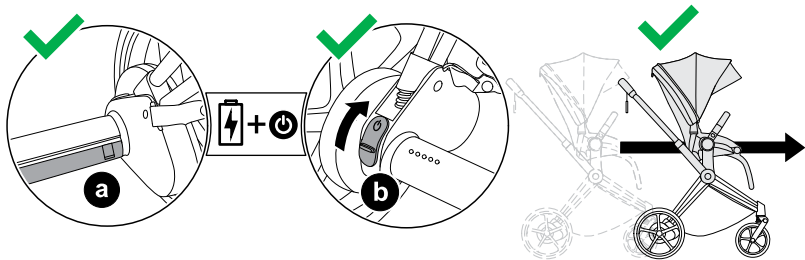

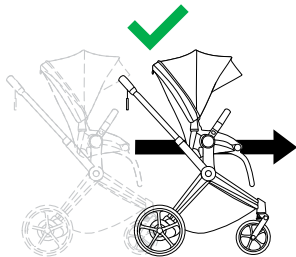
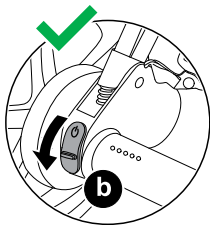
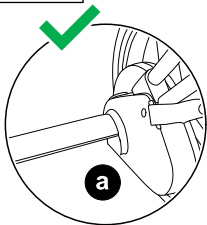

11

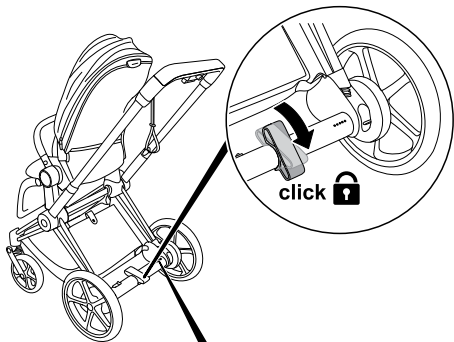

click 

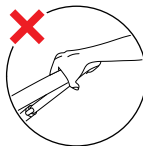
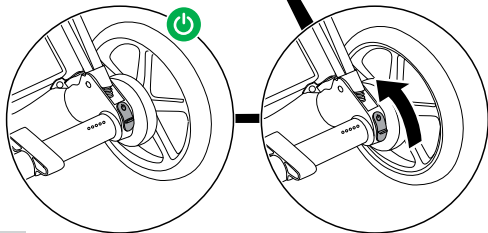

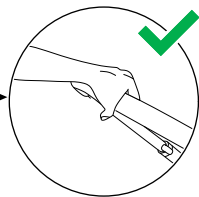
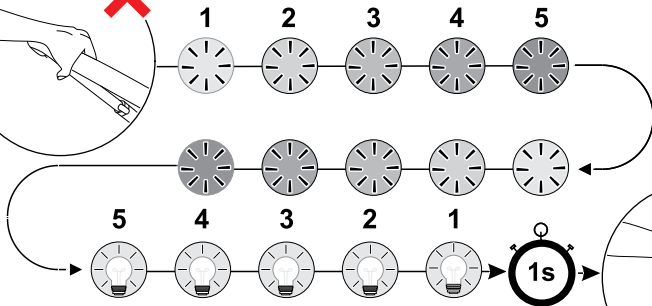
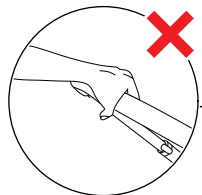
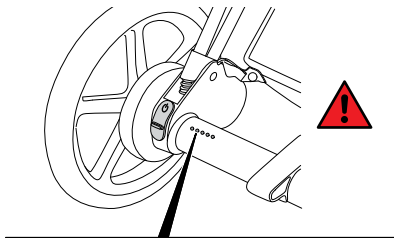
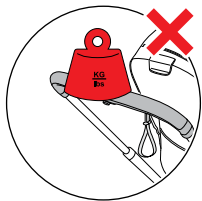

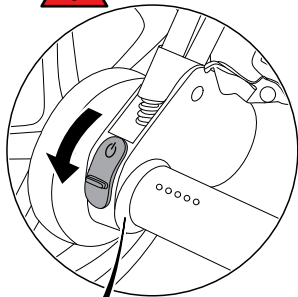
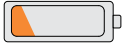
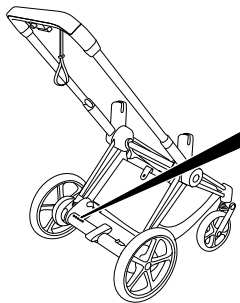

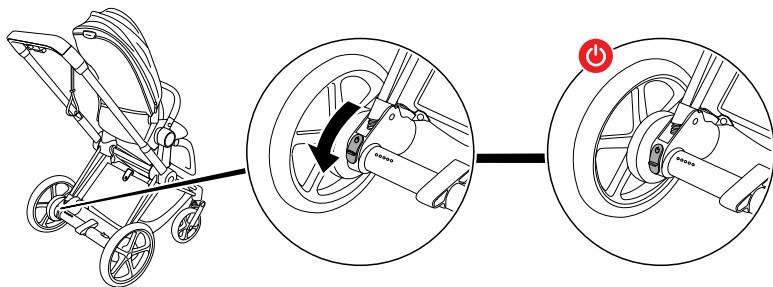

2



a



1

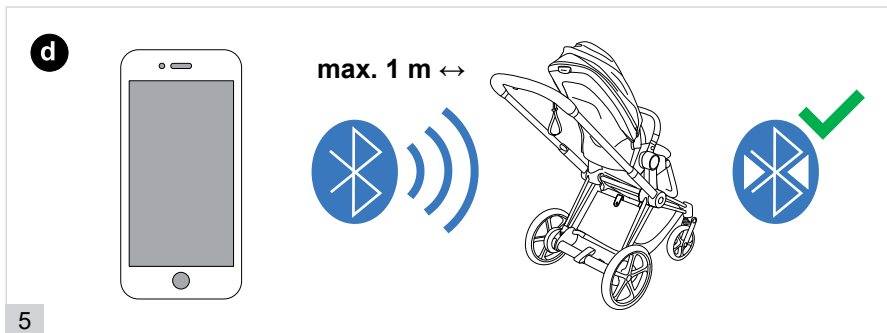
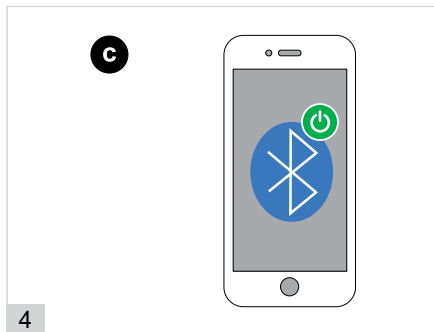
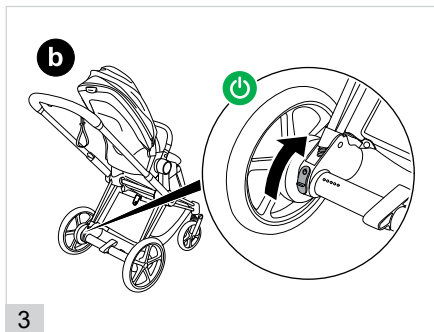



2

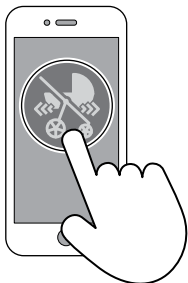

1

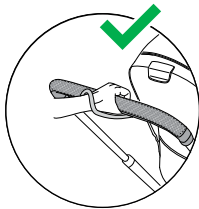
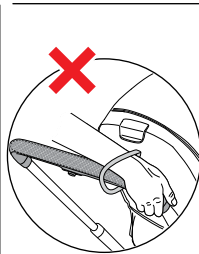
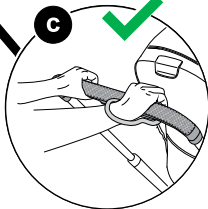
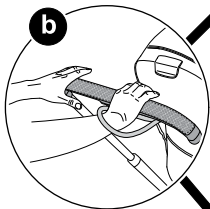
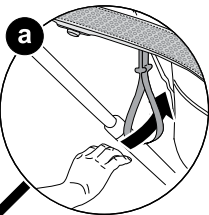
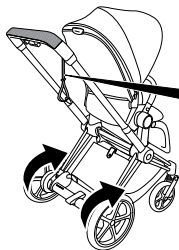

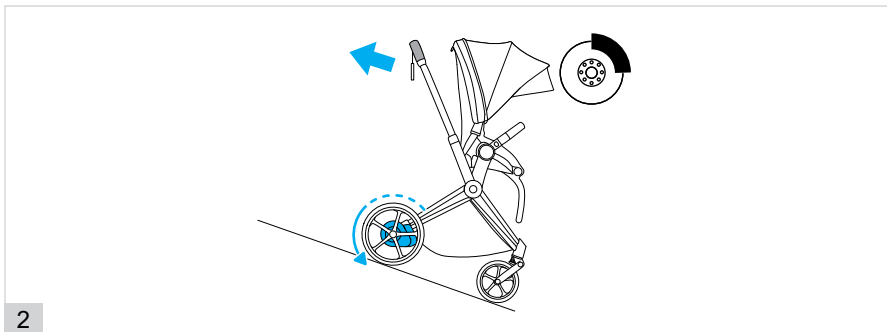
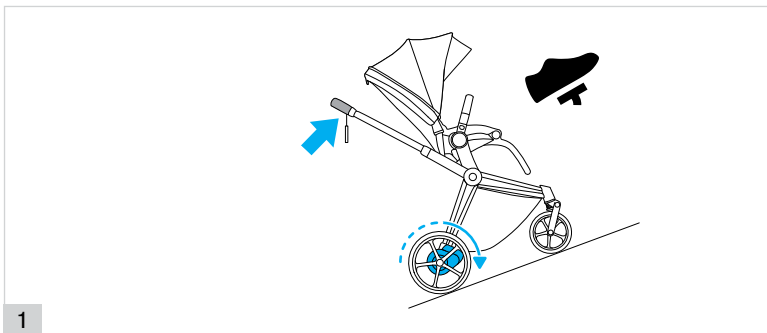

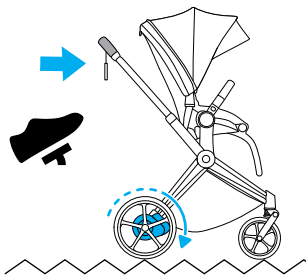

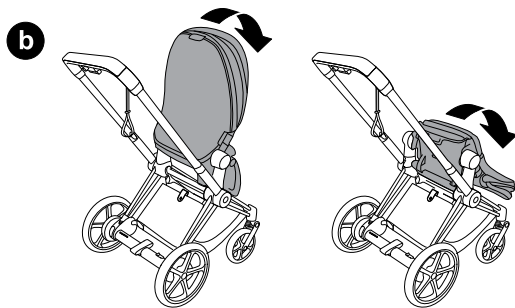
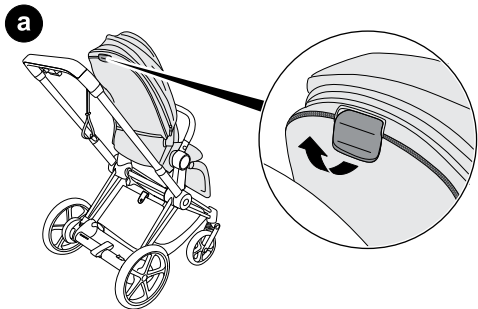

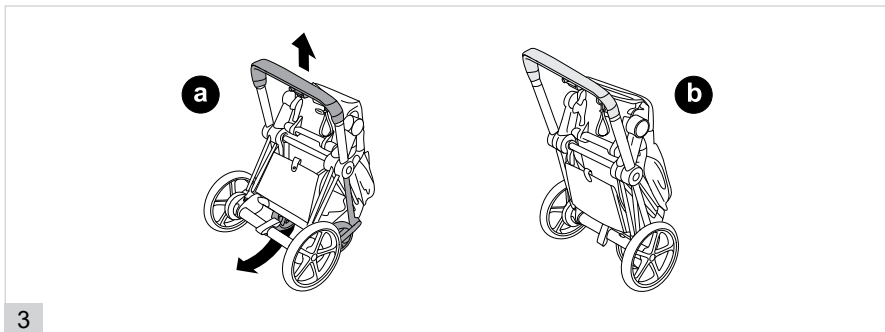
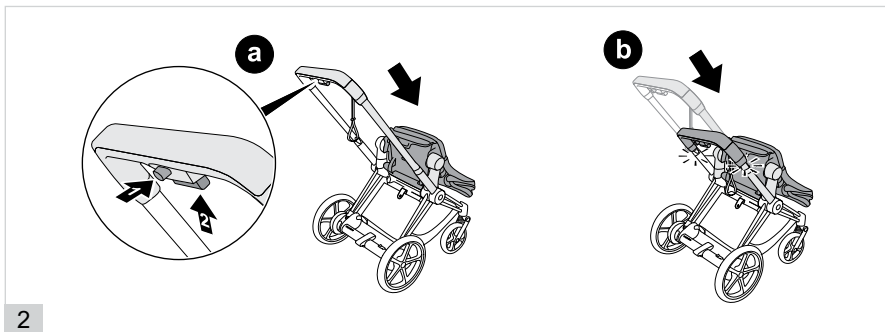

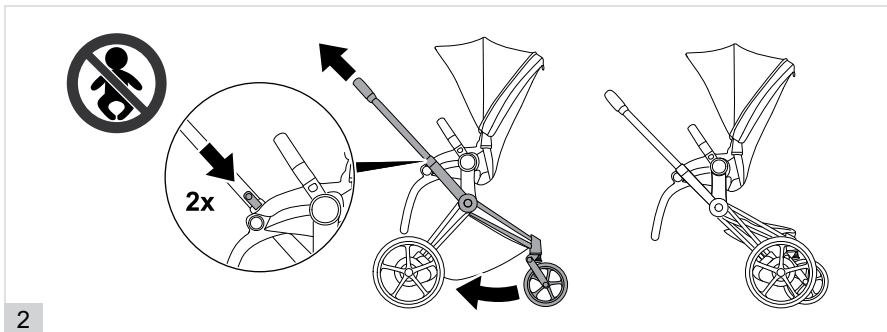
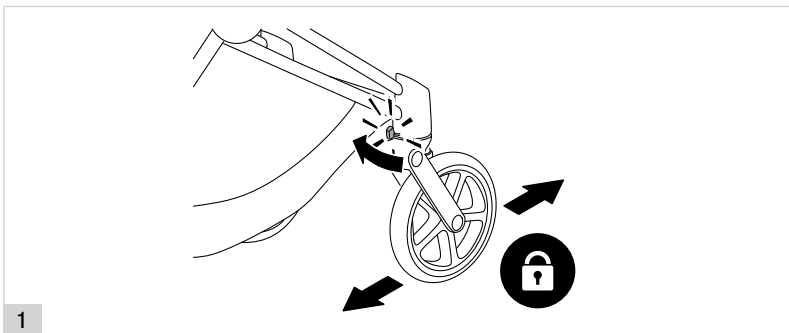

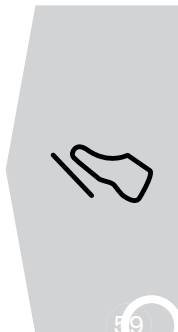
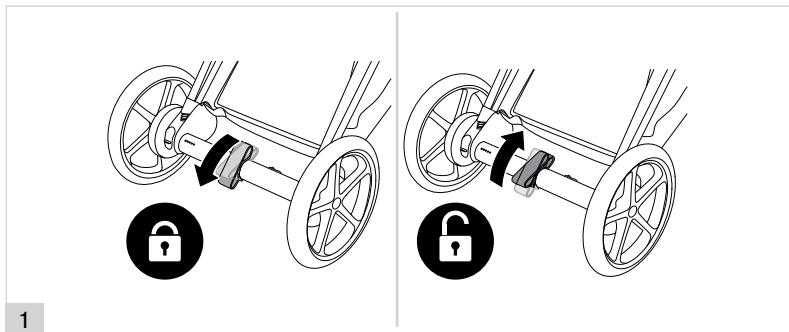
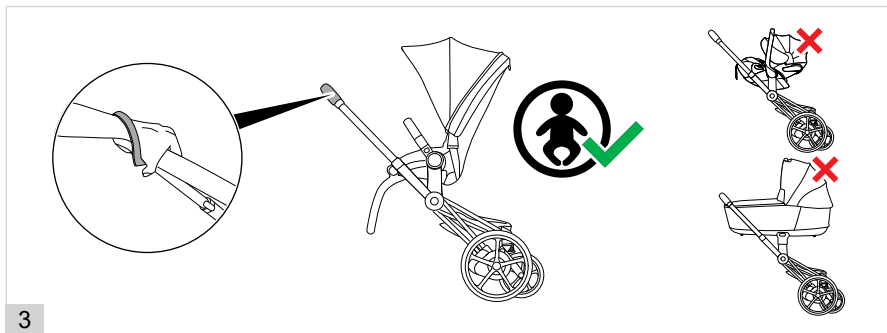

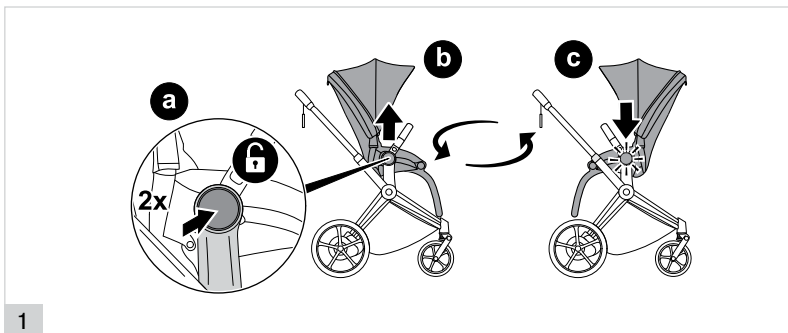
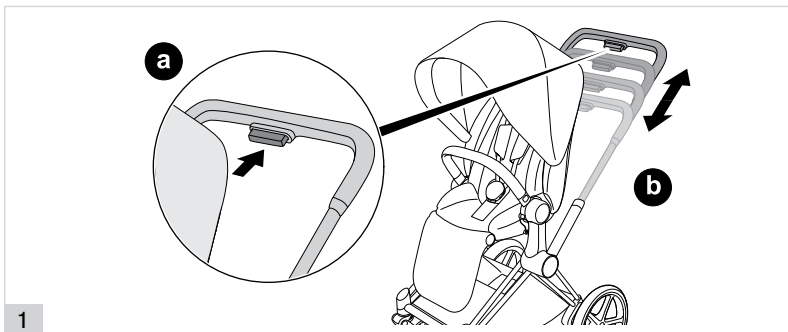

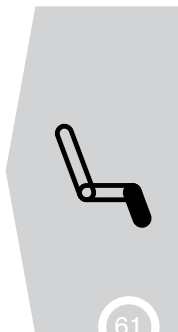
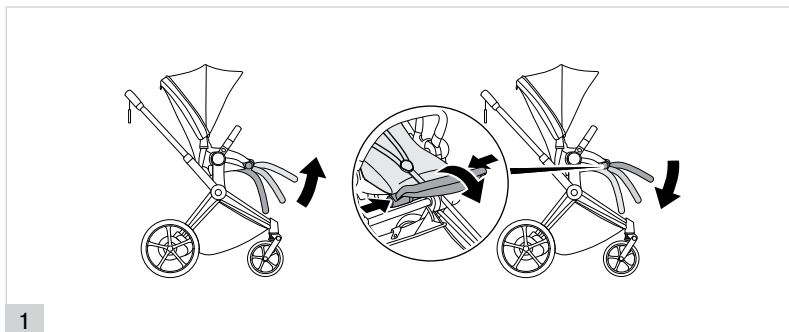
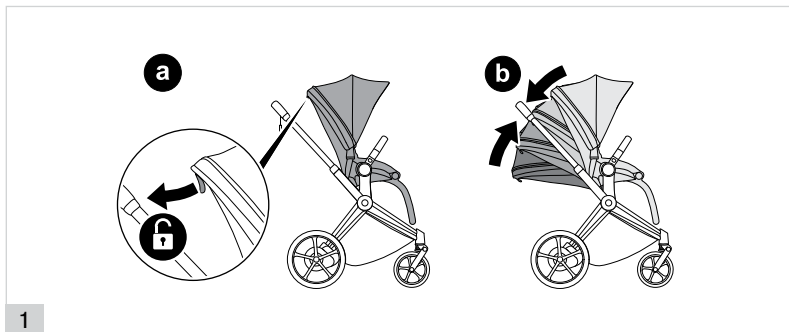

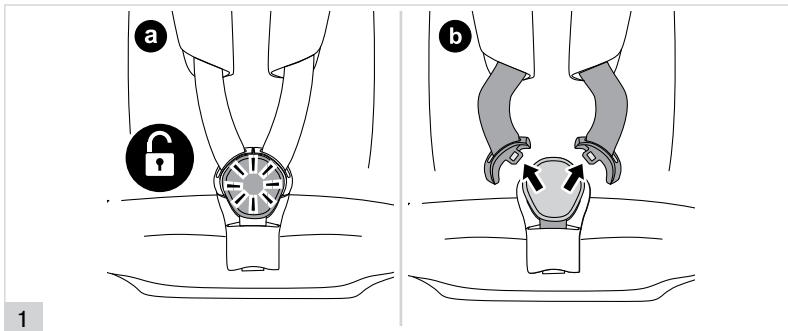
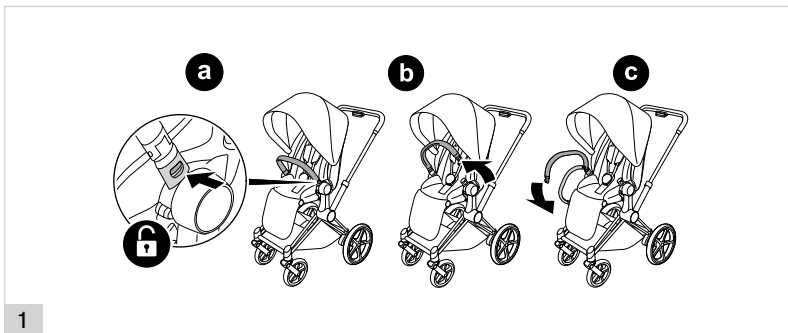

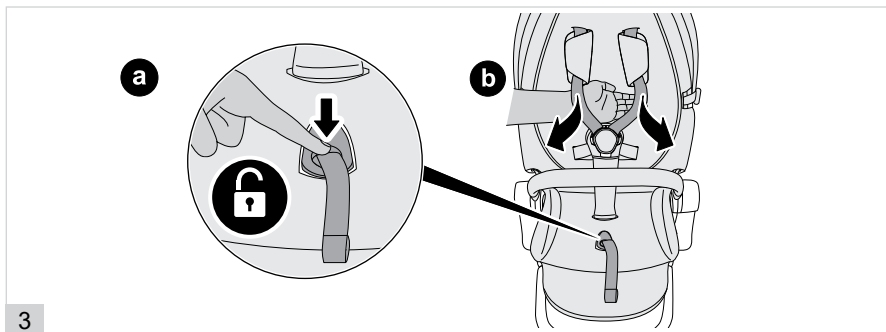
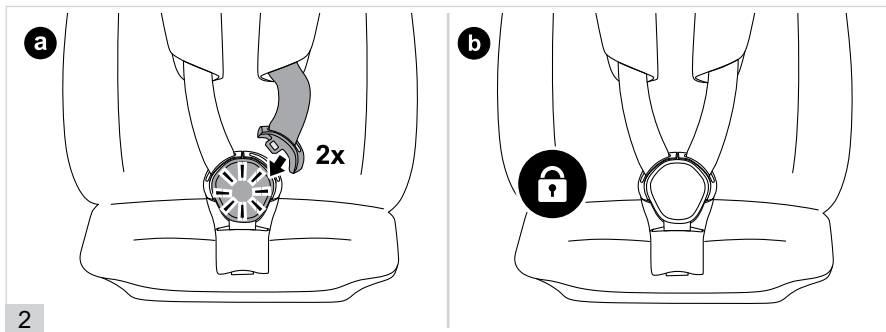

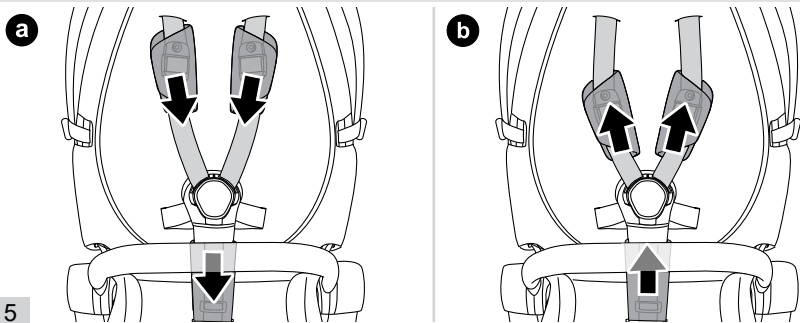
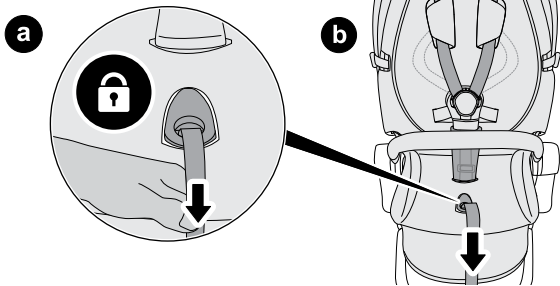

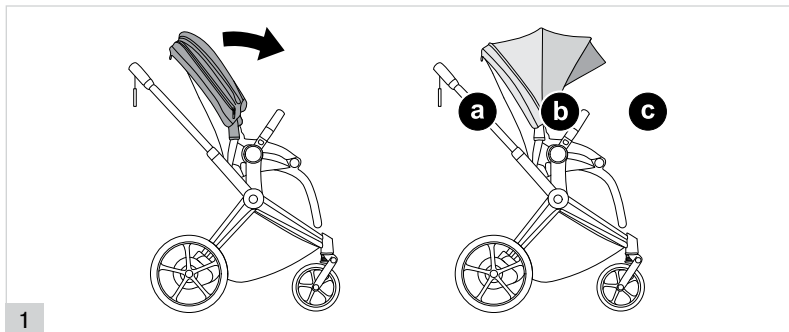
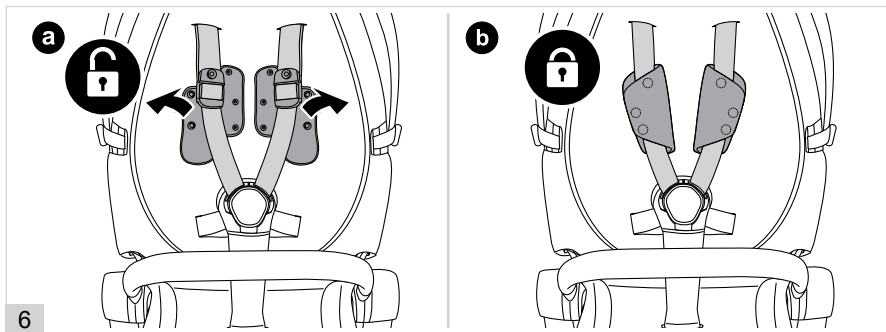

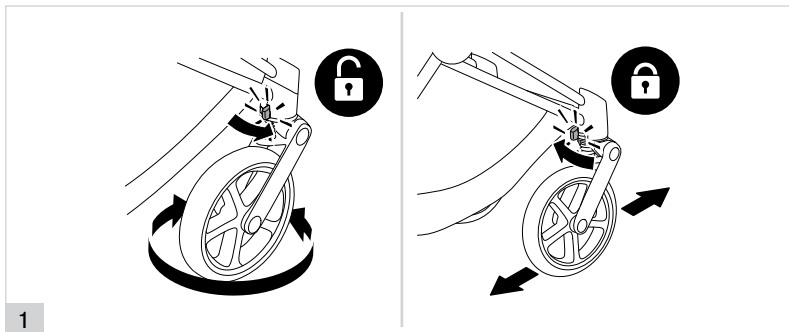
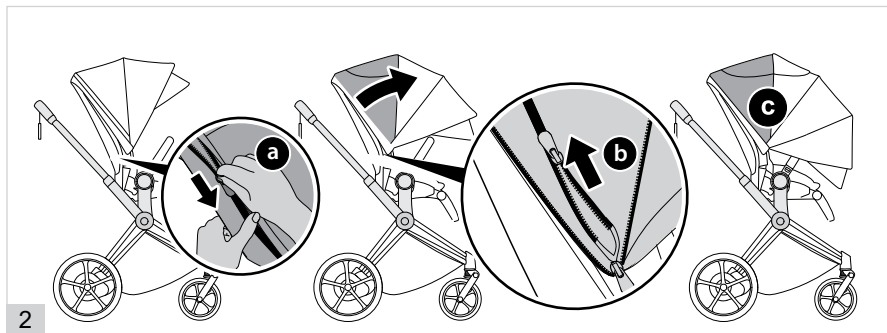

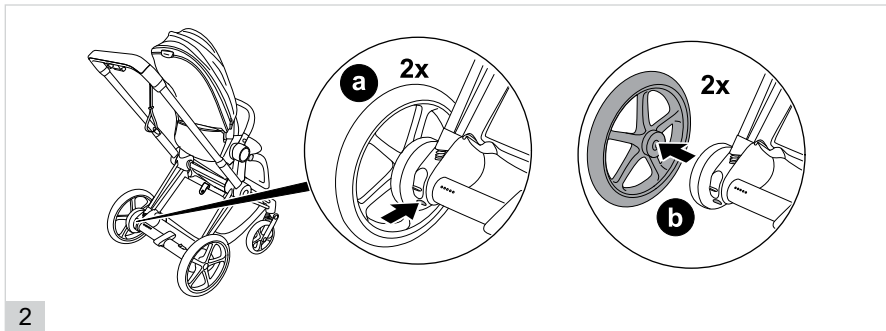
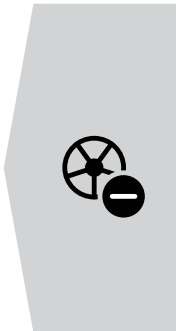
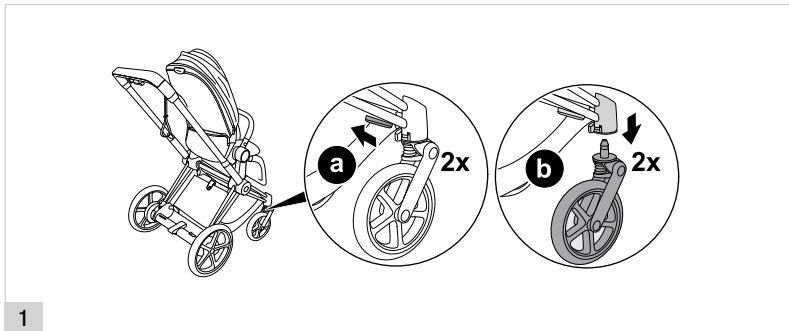

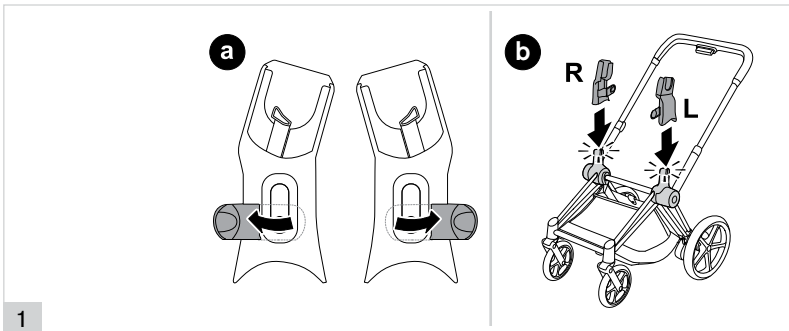
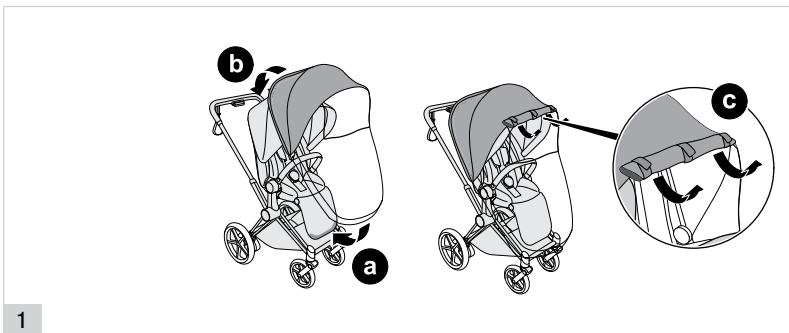

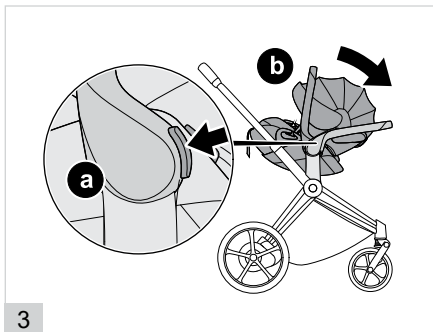

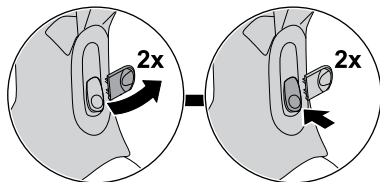

**a**

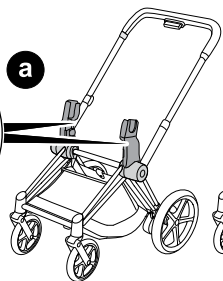

**b**

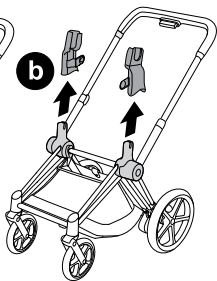

**5**

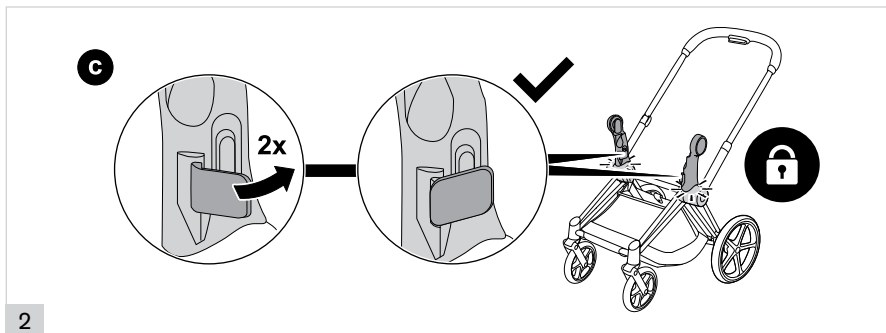
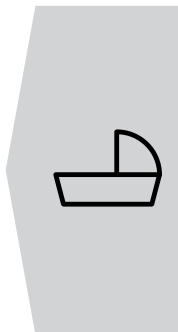
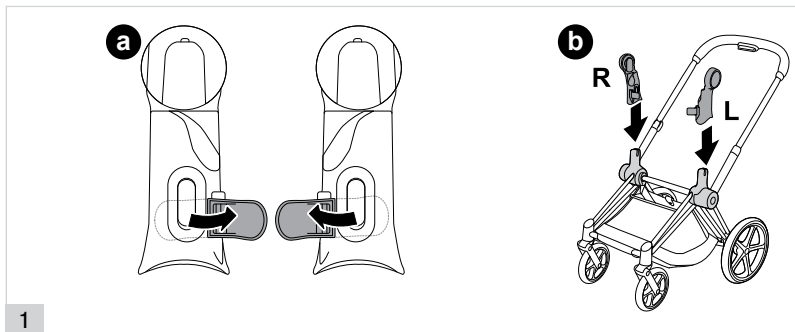

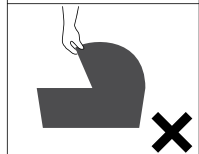
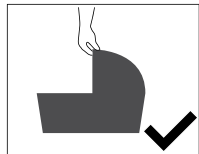
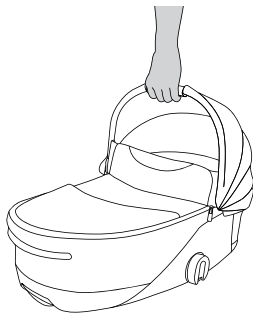
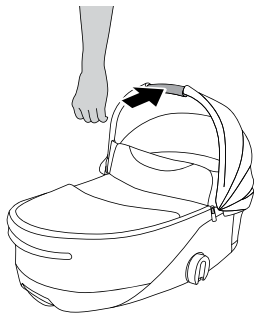

3

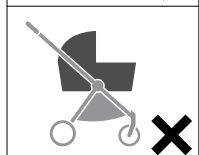
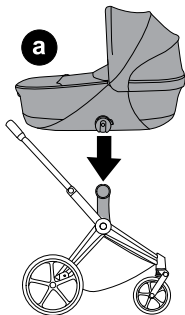

4

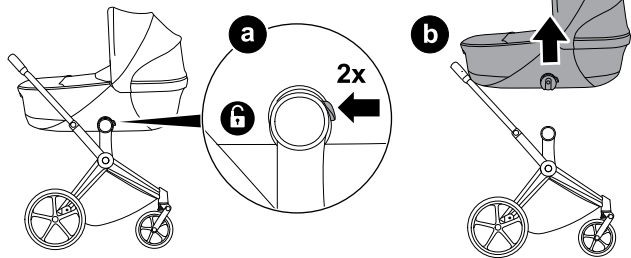

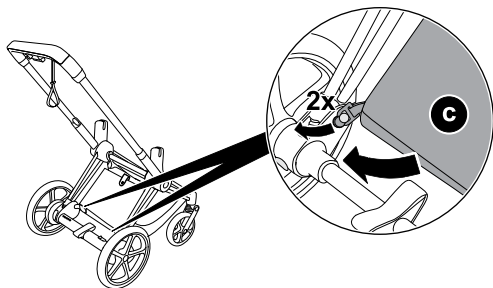
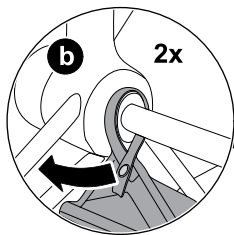

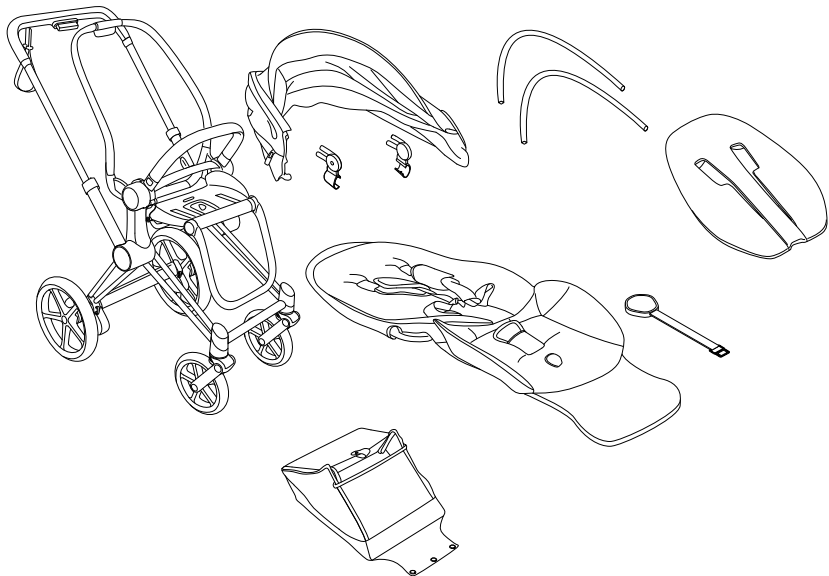



## Troubleshooting



<b>EN / DE / FR / ES</b>	<b>78</b>
<b>PT / IT / NL / PL</b>	<b>82</b>
<b>CS / SK / SL / HR</b>	<b>86</b>
<b>HU / SE / NO / FI</b>	<b>90</b>
<b>DA / ET / LV / LT</b>	<b>94</b>
<b>RU / UK / TR / EL</b>	<b>98</b>
<b>RO / IS / MT</b>	<b>102</b>
<b>AR / FA / YUE / CMN</b>	<b>106</b>
<b>JA / KO / BG / SR</b>	<b>&lt;?&gt;</b>
<b>MS / HI / TH / SQ</b>	<b>114</b>
<b>BS / ME / MK / HY / VI</b>	<b>118</b>





**Indicator lights / Kontrolllampen /  
Voyants d'indication / Luces indicadoras**

**Description / Beschreibung / Description /  
Descripción**



Only the red light flashes.

Nur die rote Lampe blinkt.

Seul le voyant rouge clignote.

Solo parpadea la luz roja.



Red light is flashing and the LED spot next to the red light shines white permantly.

Die rote Lampe blinkt und der LED Spot neben der roten Lampe leuchtet permanent in weiß.

Le voyant rouge clignote et le spot LED à côté du voyant rouge émet une lumière blanche continue.

La luz roja parpadea y el foco LED junto a la luz roja está encendido en blanco de forma permanente.



<b>Meaning / Bedeutung / Signification / Significado</b>	<b>Actions / Maßnahmen / Actions / Acciones</b>
<p>The battery is empty. The stroller will decelerate permanently.</p> <p>Die Batterie ist leer. Der Kinderwagen wird permanent abgebremst.</p> <p>La batterie est vide. La poussette va freiner en permanence.</p> <p>La batería está vacía. El carrito frenará permanentemente.</p>	<p>Please turn off the ePriam &amp; charge the battery!</p> <p>Bitte schalten Sie den ePriam aus und laden die Batterie auf!</p> <p>Veillez éteindre l'ePriam et charger la batterie !</p> <p>Apague ePriam y cargue la batería.</p>
<p>No signal from the handle bar. Support is not working anymore.</p> <p>Kein Signal von dem Schiebegriff. Unterstützung nicht mehr vorhanden.</p> <p>Pas de signal du guidon. L'assistance ne fonctionne plus.</p> <p>No hay señal procedente del manillar. El soporte no funciona.</p>	<p>Please fold &amp; unfold the stroller. If the LED status remains the same please get in touch with your retailer!</p> <p>Bitte den Kinderwagen Zusammen- und Auffalten. Bleibt der LED Status der gleiche setzen Sie sich bitte mit Ihrem Händler in Verbindung.</p> <p>Veillez plier et déplier la poussette. Si l'état du voyant LED reste le même, veuillez contacter votre revendeur.</p> <p>Pliegue y despliegue el carrito. Si el LED de estado permanece igual, póngase en contacto con su distribuidor.</p>



**Indicator lights / Kontrolllampen /  
Voyants d'indication / Luces indicadoras**

**Description / Beschreibung / Description /  
Descripción**



Red light is flashing and all 4 white LED spots are shining permanently.

Die rote Lampe blinkt und alle 4 LED Spots leuchten permanent.

Le voyant rouge clignote et les 4 spots LED blancs sont allumés en permanence.

La luz roja parpadea y los 4 focos LED están encendidos permanentemente.



<b>Meaning / Bedeutung / Signification / Significado</b>	<b>Actions / Maßnahmen / Actions / Acciones</b>
<p>Error in calibration of the handle bar sensors. Support is not working anymore.</p> <p>Kalibrierungsfehler der Sensoren im Schiebegriff. Unterstützung nicht mehr vorhanden.</p> <p>Erreur de calibrage des capteurs du guidon. L'assistance électrique ne fonctionne plus.</p> <p>Error de calibración de los sensores del manillar. El soporte no funciona.</p>	<p>Please activate the foot brake and turn off the ePriam. Remove the weight on the handle bar and do not hold the handle bar. Now turn on the ePriam again. If the LED status remains the same please get in touch with your retailer.</p> <p>Bitte betätigen Sie die Feststellbremse und schalten den ePriam aus. Entfernen Sie das Gewicht vom Schiebegriff und halten Sie nicht den Schiebegriff fest. Schalten Sie nun den ePriam wieder an. Bleibt der LED Status der gleiche setzen Sie sich bitte mit Ihrem Händler in Verbindung.</p> <p>Veillez activer la pédale de frein et éteindre l'ePriam. Retirez la pression sur le guidon et ne le tenez pas. Allumez à nouveau l'ePriam. Si l'état du voyant LED reste le même, veuillez contacter votre revendeur.</p> <p>Por favor pise el pedal de freno y apague el ePriam. Retire el peso del manillar y no mantenga sujeto el manillar. A continuación, encienda de nuevo el ePriam. Si el LED de estado permanece igual, por favor póngase en contacto con su distribuidor.</p>



**Luzes indicadoras / Indicatori luminosi /  
Indicatorlichtjes / Kontrolki**

**Descrição / Descrizione / Beschrijving / Opis**



Apenas a luz vermelha pisca.

Lampeggia solo la spia rossa.

Alleen het rode lichtje knippert.

Tylko czerwona lampka miga.



A luz vermelha pisca e o spot LED próximo da luz vermelha emite uma luminosidade branca permanente.

La spia rossa lampeggia e il LED accanto alla spia rossa diventa bianco e continuo.

Het rode licht knippert en de LED-spot naast het rode licht brandt voortdurend wit.

Czerwona kontrolka miga i punktowa lampka LED obok czerwonej kontroli świeci ciągle w białym kolorze.



<b>Significado / Significato / Betekenis / Znaczenie</b>	<b>Ações / Azioni / Acties / Działania</b>
<p>A bateria está descarregada. O carrinho diminuirá permanentemente a velocidade.</p> <p>La batteria è scarica. Il passeggino decelera in modo permanente.</p> <p>De batterij is leeg. De wandelwagen zal permanent vertragen.</p> <p>Akumulator jest rozładowany. Wózek zwolni na stałe.</p>	<p>Desligue o ePriam e carregue a bateria!</p> <p>Spegnere l'ePriam e ricaricare la batteria!</p> <p>Schakel de ePriam uit &amp; laad de batterij op.</p> <p>Wyłącz ePriam i naładuj akumulator!</p>
<p>Ausência de sinal do guiador. O suporte já não funciona.</p> <p>Nessun segnale dalla barra dell'impugnatura. L'assistenza non funziona più.</p> <p>Geen signaal van de handgreep. De ondersteuning werkt niet meer.</p> <p>Brak sygnału z rączki. Wspomaganie nie działa.</p>	<p>Rebata e abra o carrinho. Se o estado do LED permanecer sem alterações, entre em contacto com o ponto de venda!</p> <p>Ripiegare e aprire il passeggino. Se lo stato del LED non cambia, contattare il rivenditore!</p> <p>Vouw de wandelwagen op en vouw hem opnieuw open. Neem contact op met uw verkooppunt als de LED-status niet verandert.</p> <p>Złóż i rozłóż wózek. Jeśli stan diody się nie zmieni, skontaktuj się ze sprzedawcą!</p>



**Luzes indicadoras / Indicatori luminosi /  
Indicatorlichtjes / Kontrolki**

**Descrição / Descrizione / Beschrijving / Opis**



A luz vermelha pisca e os 4 spots LED brilham permanentemente.

La spia rossa lampeggia e tutti e 4 i LED bianchi sono accesi in modo continuo.

Het rode licht knippert en alle 4 witte LED-spots branden voortdurend.

Czerwona kontrolka miga i wszystkie 4 punktowe lampki LED świecą ciągle.



Significado / Significato / Betekenis / Znaczenie	Ações / Azioni / Acties / Działania
<p>Erro de calibragem dos sensores do guiador. O suporte já não funciona.</p> <p>Errore nella calibrazione dei sensori della barra dell'impugnatura. L'assistenza non funziona più.</p> <p>Fout bij het kalibreren van de sensoren van de handgreep. Ondersteuning werkt niet meer.</p> <p>Błąd kalibracji czujników w ręczce. Wspomaganie nie jest już dostępne.</p>	<p>Ative o travão de pedal e desligue o ePriam. Retire o peso do guiador e largue-o. Ligue novamente o ePriam. Se o estado do LED permanecer sem alterações, entre em contacto com o ponto de venda.</p> <p>Attivare il freno a pedale e spegnere l'ePriam. Rimuovere il peso dalla barra dell'impugnatura e non mantenerla. Ora accendere di nuovo l'ePriam. Se lo stato del LED non cambia, contattare il rivenditore.</p> <p>Activeer de voetrem en schakel de ePriam uit. Verwijder het gewicht op de handgreep en houd de handgreep niet vast. Schakel de ePriam opnieuw aan. Neem contact op met uw verkooppunt als de LED-status niet verandert.</p> <p>Uaktywnij hamulec postojowy i wyłącz ePriam. Usuń obciążenie z ręczki i nie trzymaj jej. Włącz ePriam ponownie. Jeśli stan diody się nie zmieni, skontaktuj się ze sprzedawcą.</p>



**Světelné kontrolky / Svetelné kontrolky /  
Kontrolna svjetla / Jelzőfények**

**Popis / Popis / Opis / Opis**



Bliká pouze červené světlo.

Bliká iba červené svetlo.

Utripa samo rdeča lučka.

Samo crveno svjetlo treperi.



Červené světlo bliká a LED vedle červeného světla trvale svítí bíle.

Červené svetlo bliká a LED vedľa červeného svetla trvalo svieti na bielo.

Rdeča lučka utripa, LED-dioda ob rdeči luči pa stalno sveti belo.

Crveno svjetlo treperi, a LED dioda pored crvenog svjetla stalno svijetli bijelo.



Význam / Význam / Pomen / Značenje	Akce / Úkony / Dejanja / Mjere
<p>Baterie je vybitá. Kočárek se trvale zpomalí.</p> <p>Batéria je vybitá. Kočík sa natrvalo spomalí.</p> <p>Baterija je prazna. Voziček se bo trajno upočasnil.</p> <p>Baterija je prazna. Kolica se neprekidno usporavaju.</p>	<p>Vypněte prosím kočárek ePriam a nabijte baterii.</p> <p>Vypnite kočik ePriam a nabite batériu!</p> <p>Izklopite ePriam in napolnite baterijo!</p> <p>Molimo isključite ePriam i napunite bateriju!</p>
<p>Žádný signál z rukojeti. Podpora už nefunguje.</p> <p>Žiadny signál z rukoväte. Podpora už viac nefunguje.</p> <p>Ni signala z ročice. Podpora več ne deluje.</p> <p>Nema signala s ručice. Podrška više ne funkcioniра.</p>	<p>Prosím, složte a rozložte kočárek. Pokud se stav kontrolky LED nemění, obraťte se na svého prodejce.</p> <p>Prosím, složte a rozložte kočik. Ak sa stav LED nezmení, obráťte sa na svojho predajcu!</p> <p>Voziček zložite in razprite. Če ostane LED status enak, se obrnite na prodajalca!</p> <p>Molimo sklopite i rasklopite kolica. Ako LED status ostane isti, obratite se svom prodavaču!</p>



**Světelné kontrolky / Svetelné kontrolky /  
Kontrolna svjetla / Jelzőfények**

**Popis / Popis / Opis / Opis**



Červené světlo bliká a všechny 4 bílé LED body svítí trvale.

Červené svetlo bliká a všetky 4 biele LED body svietia trvalo.

Rdeča lučka utripa in vse štiri bele LED-diode svetijo stalno.

Crveno svjetlo treperi i sve 4 bijele LED diode stalno svijetle.



Význam / Význam / Pomen / Značenje	Akce / Úkony / Dejanja / Mjere
<p>Chyba v kalibraci snímačů na rukojeti. Podpora už nefunguje.</p>	<p>Aktivujte nožní brzdu a vypněte kočárek ePriam. Odstraňte zátěž na rukojeti a pusťte ji. Nyní kočárek ePriam znovu zapněte. Pokud se stav kontrolky LED nemění, obraťte se na svého prodejce.</p>
<p>Chyba pri kalibrácii snímačov rukoväte. Podpora už viac nefunguje.</p>	<p>Aktivujte nožnú brzdú a vypnite kočík ePriam. Odstráňte záťaž na rukoväti a pustite ju. Teraz kočík ePriam znovu zapnite. Ak sa stav LED nezmení, obráťte sa na svojho predajcu.</p>
<p>Napaka umerjanja senzorjev ročice. Podpora več ne deluje.</p>	<p>Aktivirajte nožno zavoro in izklopíte ePriam. Odstranite utež na ročici in ročice ne držite. Zdaj ePriam ponovno vklopite. Če ostane LED status enak, se obrnite na prodajalca.</p>
<p>Pogreška u kalibraciji senzora ručice. Podrška više ne funkcioniira.</p>	<p>Molimo vas da aktivirate nožnu kočnicu i isključite ePriam. Uklonite uteg sa ručice i ne držite ručicu. Sada ponovo uključite ePriam. Ako LED status ostane isti, obratite se svom prodavaču!</p>



**Jelzőfények / Indikatorlampa /  
Indikatorlys / Ilmaisivalot**

**Leírás / Beskrivning / Beskrivelse / Kuvaus**



Csak a piros fény villog.

Endast den röda lampan blinkar.

Bare det røde lyset blinker.

Vain punainen valo vilkkuu.



A piros fény villog és a piros fény mellett LED spot folyamatosan fehéren világít.

Den röda lampan blinkar och LED-lampan bredvid den röda lampan lyser med fast vitt sken.

Det røde lyset blinker og LED-lyset ved siden av det røde lyset skinner fast hvitt.

Punainen valo vilkkuu ja sen vieressä oleva LED-piste loistaa valkoisena pysyvästi.



<b>Jelentés / Betydelse / Betydning / Tarkoitus</b>	<b>Eljárás / Åtgärde / Handlinger / Toiminnot</b>
<p>Az akkumulátor lemerült. A babakocsi tartósan lassulni fog.</p> <p>Batteriet är tomt. Sittvagnen kommer att sakta farten och stanna.</p> <p>Batteriet er tomt. Barnevognen vil sakke farten permanent.</p> <p>Akku on tyhjä. Rattaat hidastuvat pysyvästi.</p>	<p>Kérjük, kapcsolja ki az ePriam-ot, és töltse fel az akkumulátort!</p> <p>Stäng av ePriam och ladda batteriet!</p> <p>Slå av ePriam og lad opp batteriet!</p> <p>Sammuta ePriam ja lataa akku!</p>
<p>Nem érkezik jel a tolókarból. A támogatás már nem működik.</p> <p>Ingen signal från handtaget. Ingen hjälp ges längre.</p> <p>Ingen signal fra håndtaket. Støtten fungerer ikke lenger.</p> <p>Ei signaalia ohjaustangosta. Tuki ei enää toimi.</p>	<p>Kérjük, csukja össze és nyissa ki a babakocsit. Ha a LED állapota változatlan marad, kérjük, vegye fel a kapcsolatot a kereskedővel!</p> <p>Fäll ihop och fäll sedan upp sittvagnen igen. Om LED-lampans status förblir oförändrad ber vi dig kontakta din återförsäljare.</p> <p>Fold barnevognen sammen og ut igjen. Hvis LED-statusen holder seg lik, ta kontakt med forhandleren!</p> <p>Taita ja avaa rattaat. Jos LED-tila pysyy samana, ota yhteyttä jälleenmyyjään!</p>



**Jelzőfények / Indikatorlampa /  
Indikatorlys / Ilmaisinalot**

**Leírás / Beskrivning / Beskrivelse / Kuvaus**



A piros fény villog, és mind a 4 fehér LED spot folyamatosan világít.

Den röda lampan blinkar och alla 4 LED-lampor lyser med fast sken.

Det røde lyset blinker og alle de fire LED-lysene lyser permanent.

Punainen valo vilkkuu ja kaikki neljä valkoista LED-pistettä palavat valkoisina koko ajan.



Jelentés / Betydelse / Betydning / Tarkoitus	Eljárás / Åtgärde / Handlinger / Toiminnot
<p>A tolókar érzékelőinek kalibrálása meghibásodott. A támogatás már nem működik.</p> <p>Fel vid kalibrering av handtagets givare. Ingen hjälp ges längre.</p> <p>Feil i kalibrering av håndtakssensoren. Støtten fungerer ikke lenger.</p> <p>Ohjaustangon antureiden kalibrointivirhe. Tuki ei enää toimi.</p>	<p>Aktiválja a lábféket, és kapcsolja ki az ePriam-ot. Távolítsa el a súlyt a tolókarról, és ne tartsa a tolókart. Most kapcsolja be újra az ePriam-ot. Ha a LED állapota változatlan marad, kérjük, vegye fel a kapcsolatot a kereskedővel.</p> <p>Aktivera fotbromsen och stäng av ePriam. Ta bort vikten från handtaget och håll sedan inte i handtaget. Slå på ePriam igen. Om LED-lampornas status förbli oförändrade ber vi dig kontakta din återförsäljare.</p> <p>Aktiver fotbromsen og slå av ePriam. Fjern vekten på håndtaket og ikke hold i håndtaket. Slå deretter på ePriam på nytt. Hvis LED-statusen holder seg lik, ta kontakt med forhandleren.</p> <p>Aktivoi jalkajarru ja sammuta ePriam. Poista paino ohjaustangosta äläkä pidä siitä kiinni. Kytke nyt ePriam uudelleen päälle. Jos LED-tila pysyy samana, ota yhteyttä jälleenmyyjään..</p>



**Kontrollamper / Indikaatoruled / Gaismas indikatori / Indikatoriaus lemputės**

**Beskrivelse / Kirjeldus / Apraksts / Aprašymas**



Kun den røde lampe lyser.

Ainult punane lamp vilgub.

Mirgo vienīgi sarkanās gaismas indikators.

Mirksi tik raudona lemputė.



Den røde lampe blinker, og lysdioden ved siden af den røde lampe lyser hele tiden hvidt.

Punane lamp vilgub ja selle kõrval olev valge LED-punkt põleb pidevalt.

Mirgo sarkanās gaismas indikators un blakus esošais LED izgaismojas baltā krāsā.

Mirksi raudona lemputė ir baltai šviečia šviesos diodas šalia raudonos lemputės.



<b>Betydning / Tähendus / Skaidrojums / Reikšmė</b>	<b>Handler / Toiming / Darbība / Veiksmāi</b>
<p>Batteriet er tomt. Klapvognen vil bremse permanent.</p> <p>Aku on tühi. Jalutuskäru kiirus langeb püsivalt.</p> <p>Akumulators ir izlādējies. Bērnu ratiņi samazinās ātrumu.</p> <p>Nusilpo akumulatorius. Vežimēlis negrīžtamai sulētēs.</p>	<p>Sluk for ePriam og oplad batteriet!</p> <p>Lūlitage ePriam välja ja laadige akut.</p> <p>Lūdzu, izslēdziet ePriam un uzlādējiet akumulatoru!</p> <p>Išjunkite „ePriam“ ir įkraukite akumulatorių!</p>
<p>Intet signal fra styret. Support ikke tilgængelig mere.</p> <p>Käepidemelt ei tule signaali. Tugi ei toimi enam.</p> <p>No roktura netiek saņemts signāls. Atbalsts nedarbojas.</p> <p>Nēra signalo iš rankenos. Atrama nebeveikia.</p>	<p>Fold klapvognen sammen og ud igen. Hvis status for lysdioderne herefter er den samme, skal du kontakte forhandleren!</p> <p>Pange jalutuskäru kokku ja võtke uuesti lahti. Kui LED-punkt põleb endiselt samamoodi, pöörduge toote müüja poole!</p> <p>Lūdzu, salokiet un atlokiet bērnu ratiņus. Ja LED statuss nemainās, lūdzu, sazinieties ar izplatītāju!</p> <p>Sulankstykite ir išlankstykite vežimėlį. Jei šviesos diodas išlieka toks pats, kreipkitės į pardavėją!</p>



## Kontrolllamper / Indikaatorituled / Gaismas indikatori / Indikatoriaus lemputės

## Beskrivelse / Kirjeldus / Apraksts / Aprašymas



Den røde lampe blinker, og alle 4 hvide lysdioder lyser hele tiden.

Punane lamp vilgub ja kõik neli valget LED-punkti põlevad pidevalt.

Mirgo sarkanās gaismas indikators un visi 4 LED izgaismojas baltā krāsā.

Mirksi raudona lemputė ir visi 4 balti šviesos diodai nuolat dega.



Betydning / Tähendus / Skaidrojums / Reikšmė	Handlering / Toiming / Darbība / Veiksmāi
<p>Fejl i kalibreringen af styrets sensorer. Support ikke tilgængelig mere.</p>	<p>Aktivér fodbremseren og sluk for ePriam. Fjern vægten på styret og hold ikke ved styret. Tænd nu for ePriam igen. Hvis status for lysdioderne herefter er den samme, skal du kontakte forhandleren!</p>
<p>Käepideme andurite kalibreerimisviga. Tugi ei toimi enam.</p>	<p>Rakendage jalgpidor ja lülitage ePriam välja. Eemaldage käepidemelt raskus ja ärge hoidke käepidemest kinni. Seejärel lülitage ePriam uuesti sisse. Kui LED-punkt põleb endiselt samamoodi, pöörduge toote müüja poole.</p>
<p>Radusies roktura sensora kalibrācijas kļūme. Atbalsts nedarbojas.</p>	<p>Lūdzu, aktivizējiet kājas bremzi un izslēdziet ePriam. Atslogojiet rokturi un neturiet to. No jauna ieslēdziet ePriam. Ja LED statuss nemainās, lūdzu, sazinieties ar izplatītāju.</p>
<p>Rankenos jutiklių kalibravimo klaida. Atrama nebeveikia.</p>	<p>Ijunkite kojinių stabdį ir išjunkite „ePriam“. Perkelkite svorį nuo rankenos ir nelaikykite jos. Dabar vėl įjunkite „ePriam“. Jei šviesos diodas išlieka toks pats, kreipkitės į pardavėją.</p>



**Световые индикаторы / Світлові індикатори / Gösterge Işıkları / Φωτεινές ενδείξεις**

**Описание / Опис / Açıklama / Περιγραφή**



Мигает только красный световой индикатор.

Світиться тільки червоний індикатор.

Sadece kırmızı ışık yanıp söner.

Μόνο το κόκκινο λαμπάκι αναβοσβήνει.



Красный световой индикатор мигает, а светодиод рядом с красным световым индикатором постоянно горит белым.

Червоний індикатор мигає, а світлодіод біля червоного індикатора постійно світиться білим.

Kırmızı ışık yanıp sönüyor ve kırmızı ışığın yanındaki LED sürekli olarak beyaz yanıyor.

Το κόκκινο λαμπάκι αναβοσβήνει και το σποτάκι LED δίπλα στο κόκκινο φωτάκι είναι σταθερά αναμμένο.



Значение / Значення / Anlami / Σημασία	Действия / Дії / Eylemler / Ενέργειες
<p>Акумулятор разряжен. Детская коляска полностью сбросит скорость.</p> <p>Акумулятор розряджений. Візок постійно уповільнюватиметься.</p> <p>Pil boş. Bebek arabasının hızı sürekli azalacaktır.</p> <p>Η μπαταρία είναι άδεια. Το καροτσάκι θα σταματήσει μόλις.</p>	<p>Выключите систему ePriam и зарядите аккумулятор!</p> <p>Вимкніть ePriam та зарядіть акумулятор!</p> <p>ePriam özelliğini kapatın ve pili şarj edin!</p> <p>Απενεργοποιήστε το ePriam και αντικαταστήστε τη μπαταρία!</p>
<p>Нет сигнала от рукоятки. Поддержка больше не работает.</p> <p>Відсутній сигнал з рукоятки. Опора більше не діє.</p> <p>Kulp çubuğunda sinyal yok. Destek artık çalışmıyor.</p> <p>Δεν υπάρχει σήμα από την χειρολαβή. Η υποστήριξη δεν δουλεύει πλέον.</p>	<p>Сложите и затем разложите детскую коляску обратно. Если светодиодный индикатор останется в том же состоянии, свяжитесь с продавцом!</p> <p>Складіть та розкладіть візок. Якщо світлодіод світиться в тому самому режимі, зверніться до свого дилера!</p> <p>Bebek arabasını katlayıp tekrar açın. LED durumu aynı kalmaya devam ederse lütfen satıcınızla iletişime geçin!</p> <p>Διπλώστε και ξεδιπλώστε το καροτσάκι. Αν η κατάσταση LED παραμένει ίδια, επικοινωνήστε με τον πωλητή σας!</p>



**Световые индикаторы / Світлові  
індикатори / Gösterge Işıkları /  
Φωτεινές ενδείξεις**

**Описание / Опис / Açıklama / Περιγραφή**



Красный световой индикатор мигает, и все 4 белых светодиода постоянно горят.

Червоний індикатор мигає, а всі 4 світлодіоди постійно світяться білим.

Kırmızı ışık yanıp sönüyor ve 4 beyaz LED'in tamamı sürekli olarak yanıyor.

To κόκκινο λαμπάκι αναβοσβήνει και τα τέσσερα σποτάκια LED είναι σταθερά αναμμένα.



Значение / Значення / Anlami / Σημασία	Действия / Дії / Eylemler / Ενέργειες
<p>Ошибка калибровки сенсоров рукоятки. Поддержка больше не работает.</p> <p>Πомилка калібрування датчиків рукоятки. Опора більше не діє.</p> <p>Kulp çubuğu sensörlerinin kalibrasyonunda hata var. Destek artık çalışmıyor.</p> <p>Σφάλμα στη βαθμονόμηση των αισθητήρων της χειρολαβής. Η υποστήριξη δεν λειτουργεί πλέον.</p>	<p>Активируйте педальный тормоз и выключите ePriam. Снимите вес с рукоятки и не касайтесь рукоятки. Затем снова включите систему ePriam. Если светодиодный индикатор останется в том же состоянии, свяжитесь с продавцом!</p> <p>Активуйте педальні гальма та вимкніть ePriam. Зніміть навантаження з рукоятки и не тримайтеся за неї. Тепер знову вимкніть ePriam. Якщо світлодіод світиться в тому самому режимі, зверніться до свого дилера.</p> <p>Lütfen ayak frenini etkinleştirin ve ePriam'ı kapatın. Kulp çubuğundaki yükü kaldırın ve kulp çubuğunu tutmayın. Şimdi ePriam'ı tekrar açın. LED durumu aynı kalırsa lütfen satıcınızla iletişime geçin.</p> <p>Ενεργοποιήστε το πεντάλ του φρένου και απενεργοποιήστε το ePriam. Αφαιρέστε το βάρος από τη χειρολαβή και σταματήστε να την κρατάτε. Τώρα ενεργοποιήστε ξανά το ePriam. Εάν η κατάσταση LED παραμένει ίδια, παρακαλούμε επικοινωνήστε με τον πωλητή σας.</p>



## Lumini indicatoare / Stefnuljós / Lampu Penunjuk

## Descriere / Lýsing / Keterangan



Doar lumina roșie clipește.

Aðeins rauða ljósið blikkar.

Hanya lampu merah berkelip.



Lumina roșie clipește și LED-ul de lângă lumina roșie strălucește alb permanent.

Rauða ljósið blikkar og LED stæðan við hlið rauða ljósins skín hvít varanlega.

Lampu merah berkelip dan cahaya LED putih di sebelah lampu merah bernyala.



<b>Sens / Merking / Maksud</b>	<b>Açtioni / Aðgerð / Tindakan</b>
<p>Bateria este goală. Căruciorul va decelera permanent.</p> <p>Rafhlaðan er tóm. Vagninn mun hægja á sér þar til hann stöðvast.</p> <p>Bateri haus. Kereta sorong akan terus perlahan.</p>	<p>Vă rugăm să opriți ePriam și să încărcați bateria!</p> <p>Vinsamlegast slökkvið á ePriam og hlaðið rafhlöðuna!</p> <p>Sila matikan ePriam &amp; cas bateri!</p>
<p>Fără semnal de la mâner. Suportul nu mai funcționează.</p> <p>Ekkert merki berst frá handfangi. Stuðningur virkar ekki lengur.</p> <p>Tiada isyarat daripada bar pemegang. Sokongan tidak lagi berfungsi.</p>	<p>Vă rugăm să pliați și să desfaceți căruciorul. Dacă starea LED-ului rămâne aceeași, vă rugăm să luați legătura cu vânzătorul!</p> <p>Vinsamlegast leggjið saman og setjið upp vagninn. Ef LED merking er enn eins þá vinsamlegast hafið samband við söluaðila.</p> <p>Sila lipat &amp; buka lipatan kereta sorong. Jika cahaya LED kekal sama, hubungi pekedai anda!</p>



## Lumini indicatoare / Stefnuljós / Lampu Penunjuk



## Descriere / Lýsing / Keterangan

Lumina roșie clipește și toate cele 4 LED-uri albe strălucesc permanent.

Rauða ljósið blikkar og allar 4 hvítu LED perurnar skína varanlega.

Lampu merah berkelip dan keempat-empat cahaya LED putih bernyala.



Sens / Merking / Maksud	Acțiuni / Aðgerð / Tindakan
<p>Eroare în calibrarea senzorilor mânerului. Suportul nu mai funcționează.</p> <p>Villa við stillingu á skynjara í handfangi. Stuðningur virkar ekki lengur.</p> <p>Ralat semasa menentukur penderia bar pemegang. Sokongan tidak lagi berfungsi.</p>	<p>Vă rugăm să activați frâna de picior și să opriți ePriam. Îndepărtați greutatea de pe mâner și nu țineți mâna pe mâner.</p> <p>Acum porniți din nou ePriam.</p> <p>Dacă starea LED-ului rămâne aceeași, vă rugăm să luați legătura cu vânzătorul.</p> <p>Vinsamlegast virkið fótabremsuna og slökkvið á ePriam. Fjarlægjið lóðin af handfanginu og ekki halda í handfangið. Kveikið nú á ePriam aftur. Ef LED merking er enn sú sama þá vinsamlegast hafið samband við söluaðila.</p> <p>Sila aktifkan brek kaki dan matikan ePriam. Alihkan pemberat pada bar pemegang dan jangan pegang bar pemegang.</p> <p>Sekarang, hidupkan ePriam sekali lagi. Jika cahaya LED masih tidak berubah, sila hubungi pekedai anda.</p>



أضواء المؤشر / چراغ‌های نشانگر / 指示燈 / 指示灯

الوصف / شرح / 說明 / 说明



الضوء الأحمر فقط يومض.  
فقط چراغ قرمز چشمک می‌زند.

只有紅燈閃爍。

只有红灯闪烁。



المجاورة له تضيء باللون الأبيض بشكل دائم LED الضوء الأحمر يومض وبقعة.

کنار چراغ قرمز دائماً به رنگ سفید می‌درخشد LED نور قرمز چشمک می‌زند و نقطه.

紅燈閃爍，紅燈旁邊的 LED 光點常亮白色。

红灯闪烁，红灯旁边的 LED 光点常亮白色。



المعنى / مفهوم / 意義 / 意义	الإجراءات / اقدامات / 操作 / 操作
<p>البطارية فارغة. سرعة عربة الأطفال ستبتاطأ بشكل دائم.</p> <p>باترى خالى است. سرعت كالكسه متناوبا كاهش مى يابد.</p> <p>電池沒電了。嬰兒車將永久減速。</p> <p>電池沒電了。嬰兒車將永久減速。</p>	<p>وشحن البطارية ePriam يُرجى إيقاف تشغيل!</p> <p>را خاموش و باترى را شارژ كنيد ePriam لطفا!</p> <p>請關閉 ePriam 並給電池充電!</p> <p>請关闭 ePriam 并給電池充電!</p>
<p>لا توجد إشارة من شريط المقبض. لن يعمل الدعم بعد الآن.</p> <p>هیچ سیگنالی از دسته دریافت نمی شود. پشتیبانی دیگر کارایی ندارد.</p> <p>手柄杆沒有信號。 支架不起作用了。</p> <p>手柄杆沒有信號。 支架不起作用了。</p>	<p>يُرجى طي عربة الأطفال ثم فتحها.</p> <p>كما هي، يرجى الاتصال ببائع التجزئة الذي تتعامل معه LED إذا ظلت حالة!</p> <p>لطفا كالكسه را تا و دوباره باز كنيد.</p> <p>ثابت ماند، لطفا با فروشنده تماس بگیريد LED اگر وضعیت!</p> <p>請折疊然後再展開嬰兒車。 如果 LED 燈狀態保持不變，請與您的經銷商聯繫！</p> <p>請折疊然後再展開嬰兒車。 如果 LED 燈狀態保持不變，請與您的經銷商聯繫！</p>



أضواء المؤشر / چراغ‌های نشانگر / 指示灯 / 指示灯

الوصف / شرح / 說明 / 说明



البيضاء الأربعة تضيء بشكل دائم LED الضوء الأحمر يومض وجميع نقاط.

به طور دائمی می‌درخشند LED چراغ قرمز چشمک می‌زند و هر 4 نقطه سفید.

紅燈閃爍，所有 4 個白色 LED 燈光點將永久閃爍。

紅灯閃爍，所有 4 个白色 LED 灯光点將永久閃爍。



المعنى / مفهوم / 意義 / 意义	الإجراءات / اقدامات / 操作 / 操作
<p>خطأ في معايرة مستشعرات شريط المقبض. لن يعمل الدعم بعد الآن.</p> <p>خطا در کالیبراسیون حسگرهای دسته. پشتیبانی دیگر کارایی ندارد.</p> <p>手柄杆感測器校準時出錯。支架不起作用了。</p> <p>手柄杆传感器校准时出错。支架不起作用了。</p>	<p>ePriam يُرجى تنشيط مكابح القدم وإيقاف تشغيل. قم بإزالة الوزن الموجود على شريط المقبض ولا تمسك به. مرة أخرى ePriam قم الآن بتشغيل. كما هي، فيرجى الاتصال ببائع التجزئة الذي تتعامل معه LED إذا ظلت حالة.</p> <p>را خاموش کنید ePriam لطفاً ترمز دستى را فعال کرده و. وزن را از روی دسته بردارید و دسته را نگیرید. را روشن کنید ePriam حالا دوباره. تغییر نکرد، لطفاً با فروشنده تماس بگیرید LED اگر وضعیت.</p> <p>請啟動腳剎並關閉 ePriam。卸下手柄杆上的重物，不要握住手柄杆。現在再次打開 ePriam。如果 LED 燈狀態保持不變，請與您的經銷商聯繫。</p> <p>请启动脚刹并关闭 ePriam。卸下手柄杆上的重物，不要握住手柄杆。现在再次打开 ePriam。如果 LED 灯状态保持不变，请与您的经销商联系。</p>



インジケータ ランプ / 표시등 / Светлини  
индикатори / Kontrolne lampice

説明 / 설명 / Описание / Opis



赤いランプだけ点滅する。

붉은 등만 깜빡임.

Мига само червената светлина.

Samo crvena lampica treperi.



赤いランプが点滅し、赤色のランプの隣にあるLEDランプは  
白く連続点灯する。

붉은 등이 깜빡이고 붉은 등 옆의 LED 부분에 흰색 불이  
계속 켜져 있음.

Червената светлина мига, а светодиодът до червената  
светлина свети постоянно в бяло.

Crvena lampica treperi, a LED dioda pored crvene lampice  
stalno svetli belo.



意味 / 의미 / Значение / Značenje	対応策 / 동작 / Действия / Mere
<p>バッテリーの残量がありません。ベビーカーは減速して止まります。</p> <p>배터리가 없음. 유아차의 속도가 영구적으로 줄어 듭니다.</p> <p>Батерията е изтощена. Детската количка ще се движи все по-бавно.</p> <p>Baterija je prazna. Kolica se neprekidno usporavaju.</p>	<p>ePriamの電源を切って充電してください。</p> <p>ePriam을 끄고 배터리를 충전하세요!</p> <p>Моля изключете ePriam и заредете батерията!</p> <p>Molimo isključite ePriam i napunite bateriju!</p>
<p>ハンドルバーからのシグナルがありません。支持機能が動作していません。</p> <p>핸들 바에 신호가 없음. 서포트가 더 이상 작동하지 않음.</p> <p>Липсва сигнал от дръжката. Опората вече не работи.</p> <p>Nema signala sa ručice. Podrška više ne funkcioniše.</p>	<p>ベビーカーを折りたたんでから広げてください。LEDランプの状態が変わらない場合は、お買い上げの店舗にお問い合わせください。</p> <p>유아차를 접었다가 펴세요. LED가 계속 같은 상태로 유지된다면 판매점에 문의하세요!</p> <p>Моля сгънете и разгънете детската количка. Ако статусът на светодиода остане същият, моля свържете се с Вашия дистрибутор!</p> <p>Molimo sklopite i rasklopite kolica. Ako LED status ostane isti, obratite se svom prodavcu!</p>



インジケータ ランプ / 표시등 / Светлини  
индикатори / Kontrolne lampice

説明 / 설명 / Описание / Opis



赤いランプが点滅し、4つの白いLEDランプは連続点灯している。

붉은 등이 깜빡이고 4개의 흰색 LED에 모두 불이 켜져 있음.

Червената светлина мига, а всички четири светодиода светят постоянно.

Crvena lampica treperi i sve 4 bele LED diode kontinuirano svetle.



意味 / 의미 / Значение / Značenje	対応策 / 동작 / Действия / Mere
<p>ハンドルバーセンサーのキャリブレーション中にエラーが発生しました。支持機能が動作していません。</p> <p>핸들 바 센서의 보정에 오류가 있음. 서포트가 더 이상 작동하지 않음.</p> <p>Грешка в калибрирането на датчиците на дръжката. Поддръжката вече не работи.</p> <p>Greška u kalibraciji senzora ručice. Podrška više ne funkcionise.</p>	<p>フットブレーキを作動させてePriamの電源を切ってください。ハンドルバーに荷重がかからないようにし、ハンドルバーから手を離してください。次にePriamの電源を入れなおしてください。LEDランプの状態が変わらない場合は、お買い上げの店舗にお問い合わせください。</p> <p>풋 브레이크를 작동하고 ePriam을 끄세요. 핸들 바의 하중을 제거하고 핸들 바를 잡지 마세요. 이제 ePriam을 다시 켜세요. LED가 계속 같은 상태로 유지된다면 판매점에 문의하세요.</p> <p>Моля активирайте крачната спирачка и изключете ePriam. Отстранете тежестите от дръжката и не я дръжте. Включете отново ePriam. Ако статусът на светодиодите остане същият, моля свържете се с Вашия дистрибутор.</p> <p>Aktivirajte nožnu kočnicu i isključite ePriam. Uklonite teg sa ručice i ne držite ručicu. Sada ponovo uključite ePriam. Ako LED status ostane isti, obratite se svom prodavcu!</p>



Lampu Penunjuk / संकेतक बत्तियाँ / ไฟแสดงสถานะ / Dritat treguese

Keterangan / विवरण / คำอธิบาย / Përshkrim



Hanya lampu merah berkelip.

केवल लाल बत्ती जलती है।

มีเพียงไฟสีแดงกะพริบ

Vetëm drita e kuqe pulson.



Lampu merah berkelip dan cahaya LED putih di sebelah lampu merah bernyala.

लाल बत्ती जल रही है और लाल बत्ती के बगल में स्थित LED स्थायी रूप से सफेद है।

ไฟสีแดงกะพริบและจุด LED ข้างไฟสีแดงจะสว่างเป็นสีขาวอย่างถาวร

Drita e kuqe pulson dhe spoti LED pas dritës së kuqe qëndron e ndezur në ngjyrë të bardhë.



Maksud / अर्थ / ความหมาย / Çfarë do të thotë	Tindakan / कार्रवाई / การดำเนินการ / Veprimet
<p>Bateri haus. Kereta sorong akan terus perlahan.</p> <p>बैटरी खाली है। स्ट्रोलर स्थायी रूप से धीमा हो जाएगा।</p> <p>แบตเตอรี่หมด รถเข็นเด็กจะชะลอความเร็วอย่างถาวร</p> <p>Bateria është bosh. Karroca do të ngadalësohet përfundimisht.</p>	<p>Sila matikan ePriam &amp; cas baterai!</p> <p>कृपया ePriam बंद करें और बैटरी चार्ज करें!</p> <p>โปรดปิด ePriam และชาร์จแบตเตอรี่!</p> <p>Ju lutem fikeni ePriam dhe karikoni baterinë!</p>
<p>Tiada isyarat daripada bar pemegang. Sokongan tidak lagi berfungsi.</p> <p>हैंडल बार से कोई संकेत नहीं। सपोर्ट अब काम नहीं कर रहा है।</p> <p>ไม่มีสัญญาณจากแฮนด์บาร์ การสนับสนุนไม่สามารถใช้ได้อีกต่อไป</p> <p>Nuk ka sinjal nga shufra e dorezës. Mbështetja nuk funksionon më.</p>	<p>Sila lipat &amp; buka lipatan kereta sorong. Jika cahaya LED kekal sama, hubungi pekedai anda!</p> <p>कृपया स्ट्रोलर को मोड़ें और फिर खोलें। यदि LED की स्थिति समान रहती है तो कृपया अपने खुदरा विक्रेता से संपर्क करें!</p> <p>กรุณาพับและกางรถเข็นออก หากสถานะ LED ยังคงเหมือนเดิม โปรดติดต่อผู้ค้าปลีกของคุณ!”</p> <p>Ju lutem paloseni dhe shpaloseni karrocën. Nëse gjendja e dritës LED mbetet njëjëlloj, ju lutemi të kontaktoni shitësin!</p>



Lampu Penunjuk / संकेतक बतियाँ / ไฟแสดงสถานะ / Dritat treguese

Keterangan / विवरण / คำอธิบาย / Përshkrim



Lumina roșie clipește și toate cele 4 LED-uri albe strălucesc permanent.

लाल बत्ती जल रही है और सभी 4 सफेद LED स्पॉट स्थायी रूप से जल रहे हैं।

ไฟสีแดงกะพริบและจุด LED สีขาวทั้ง 4 จุดสว่างอย่างถาวร

Drita e kuqe pulson dhe të 4 spotet LED qëndrojnë ndezur.



Maksud / अर्थ / ความหมาย / Çfarë do të thotë	Tindakan / कार्रवाई / การดำเนินการ / Veprimet
<p>Eroare în calibrarea senzorilor mânerului. Suportul nu mai funcționează.</p> <p>हैंडल बार सेंसर के कैलीब्रेशन में त्रुटि। सपोर्ट अब काम नहीं कर रहा है।</p> <p>เกิดข้อผิดพลาดในการปรับเทียบเซ็นเซอร์ของแฮนด์บาร์ การสนับสนุนไม่สามารถใช้ได้อีกต่อไป</p> <p>Gabim në kalibrimin e sensorëve të shufrës mbajtëse. Mbështetja nuk punon më.</p>	<p>Vă rugăm să activați frâna de picior și să opriți ePriam. Îndepărtați greutatea de pe mâner și nu țineți mâna pe mâner. Acum porniți din nou ePriam. Dacă starea LED-ului rămâne aceeași, vă rugăm să luați legătura cu vânzătorul.</p> <p>कृपया फुट ब्रेक को सक्रिय करें और ePriam को बंद करें। हैंडल बार से भार हटा दें और हैंडल बार को न पकड़ें। अब ePriam को फिर से चालू करें। यदि LED की स्थिति समान रहती है तो कृपया अपने खुदरा विक्रेता से संपर्क करें।</p> <p>โปรดเปิดใช้งานเบรกเท้าและปิด ePriam จากนั้นนำ ตัวถ่วงน้ำหนักบนแฮนด์บาร์ออกและอย่าจับแฮนด์ บาร์ คราวนี้เปิด ePriam อีกครั้ง หากสถานะ LED ยังคง เหมือนเดิม โปรดติดต่อผู้ค้าปลีกของคุณ</p> <p>Ju lutem aktivizoni frenën e këmbës dhe fikeni ePriam. Hiqeni peshën në dorezën mbajtëse dhe mos e mbani dorezën mbajtëse. Tani ndizeni ePriam përsëri. Nëse statusi i dritës LED nuk ndryshon, ju lutem kontaktoni shitësin.</p>



**Kontrolne lampice / Kontrolne lampice /  
Индикаторски светла / Ցուցիչ լույսեր**

**Opis / Opis / Опис / նկարագիր**



Samo crvena lampica treperi.

Samo crvena lampica treperi.

Трепка само црвеното светло.

Միայն կարմիր լույսն է թարթում:

Chỉ có đèn đỏ nhấp nháy.



Crvena lampica treperi, a LED dioda pored crvene lampice stalno svijetli bijelo.

Crvena lampica treperi, a LED dioda pored crvene lampice stalno svijetli bijelo.

Црвеното светло трепка и ЛЕД-точката што се наоѓа до црвеното светло свети постојано со бела боја.

Կարմիր լույսը թարթում է, իսկ կարմիր լույսի կողմին գտնվող LED կետը մշտապես սպիտակ է:

Đèn đỏ nhấp nháy và tín hiệu LED bên cạnh đèn đỏ sáng trắng.



Značenje / Značenje / Значење / նշանակություն	Mjere / Mjere / Дејства / Գործողություններ
<p>Baterija je prazna. Kolica se neprekidno usporavaju.</p> <p>Baterija je prazna. Kolica se neprekidno usporavaju.</p> <p>Батеријата е празна. Количката ќе се забави трајно.</p> <p>Մարտկոցը դատարկ է: Մանկատալակը դանդաղելով կանգ կառնի:</p> <p>Hết pin. Xe đầy sẽ luôn đi chậm lại. .</p>	<p>Molimo isključite ePriam i napunite bateriju!</p> <p>Molimo isključite ePriam i napunite bateriju!</p> <p>Исклучете го ePriam и наполнете ја батеријата!</p> <p>Խնդրում ենք անջատել ePriam-ը և լիցքավորել մարտկոցը:</p> <p>Vui lòng tắt ePriam &amp; sạc pin!</p>
<p>Nema signala s ručice. Podrška više ne funkcioniše.</p> <p>Nema signala sa ručice. Podrška više ne funkcioniše.</p> <p>Нема сигнал од рачката. Поддршката повеќе не функционира.</p> <p>Բռնակի ձողից ազդանշան չկա: Աջակցությունն այլևս չի գործում:</p> <p>Không có tín hiệu từ thanh tay lái. Phần đỡ không còn có tác dụng.</p>	<p>Molimo sklopite i rasklopite kolica. Ako LED status ostane isti, obratite se svom prodavcu!</p> <p>Molimo sklopite i rasklopite kolica. Ako LED status ostane isti, obratite se svom prodavcu!</p> <p>Скlopете ја и отворете ја количката. Ако статусот на ЛЕД продолжи да биде ист, контактирајте со продавачот!</p> <p>Խնդրում ենք ծալել և բացել մանկատալակը: Եթե LED-ի կարգավիճակը մնա նույնը, կապվե՛ք ձեր վաճառողի հետ:</p> <p>Vui lòng gấp lại rồi mở xe đẩy ra. Nếu trạng thái LED vẫn không đổi, vui lòng liên lạc với bên bán lẻ của quý vị!</p>



**Kontrolne lampice / Kontrolne lampice /  
Индикаторски светла / Ցուցիչ լույսեր / Đèn  
của bộ phận đèn chỉ báo**

**Opis / Opis / Опис / նկարագիր / Mô tả**



Crvena lampica treperi i sve 4 bijele LED diode stalno svijetle.

Crvena lampica treperi i sve 4 bijele LED diode stalno svijetle.

Црвеното светло трепка и сите 4 бели ЛЕД-точки светат постојано.

Կարմիր լույսը թարթում է, և բոլոր 4 սպիտակ LED կետերը մշտապես վառվում են:

Đèn đỏ nhấp nháy và tất cả 4 tín hiệu LED màu trắng bật sáng đều.



Značenje / Značenje / Значење / նշանակություն / Ý nghĩa	Mjere / Mjere / Дејства / Գործողություններ / Việc cần làm
<p>Greška u kalibraciji senzora ručice. Podrška više ne funkcioniše.</p> <p>Greška u kalibraciji senzora ručice. Podrška više ne funkcioniše.</p> <p>Грешка при калибрација на сензорите на рачката. Поддршката повеќе не работи.</p> <p>Բռնակի ձողի սվիչների կալիբրացիայի սխալ: Աջակցությունն այլևս չի գործում:</p> <p>Lỗi xác định các bộ cảm biến trên thanh tay lái. Phần đỡ không còn có tác dụng.</p>	<p>Aktivirajte nožnu kočnicu i isključite ePriam. Uklonite teg sa ručice i ne držite ručicu. Sada ponovo uključite ePriam. Ako LED status ostane isti, obratite se svom prodavcu!</p> <p>Aktivirajte nožnu kočnicu i isključite ePriam. Uklonite teg sa ručice i nemojte držati ručicu. Sada ponovo uključite ePriam. Ako LED status ostane isti, obratite se svom prodavcu!</p> <p>Активирајте ја ножната сопирачка и исклучете го ePriam. Престанете да ја притискате и да ја држите рачката. Сега, вклучете го ePriam повторно. Ако статусот на ЛЕД-точката остане ист, контактирајте со продавачот.</p> <p>Խնդրում ենք անջատել ստեպարի արգելակը և անջատել ePriam-ը:</p> <p>Հետո ցրեք բռնակի ձողի ծանրությունը և մի պահեք բռնակի ձողը: Այժմ նորից անցրեք ePriam-ը:</p> <p>Եթե LED- ի կարգավիճակը մնում է հույսը, կապվեք ձեր մանրածախ վաճառողի հետ:</p> <p>Vui lòng kích hoạt phanh chân và tắt ePriam. Tránh đè lên tay lái và không nắm lấy thanh tay lái. Bây giờ bật lại ePriam. Nếu trạng thái LED vẫn không đổi, vui lòng liên lạc với bên bán lẻ của quý vị.</p>



CYBEX GmbH

Riedingerstr. 18 | 95448 Bayreuth | Germany  
+49 (0) 921-78 511-0 | [info@cybex-online.com](mailto:info@cybex-online.com)

[www.cybex-online.com](http://www.cybex-online.com)

